

High-efficiency full inverter compact outdoor packaged units

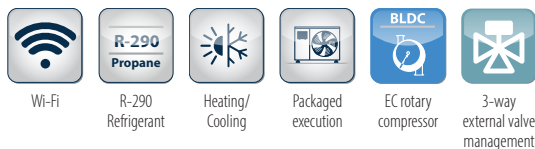

## MLP 06 - 30 kW



### PLUS

- » Twin-rotary compressor driven by an electric EC motor
- » EC hydraulic pump
- » EC axial fan
- » Advanced system management and adjustment strategies
- » Access to tax deductions
- » Very Low GWP natural refrigerant
- » Production of hot water up to 75°C

### High efficiency full inverter heat pumps

MLP is a range of heat pumps consisting of 7 unit sizes and 9 models, equipped with a latest generation inverter compressor capable of satisfying the requests for cooling, heating and DHW production power in buildings in the most efficient way residential or light commercial. Thanks to the use of R290, MLP heat pumps guarantee high performance with wide working ranges. The high seasonal efficiencies and the very low GWP make it the ideal product for achieving thermo-hygrometric well-being while fully respecting the environment.

All models, that access to tax deductions prouded for by actual law, takes full advantage of some of the most innovative HVAC technologies: in fact, all the units are full-inverter and the extended use of electrical motors with permanent magnets driven by inverters with direct current, even for the accessory components – such as fans and water circulators – drastically reduces electrical power consumption and minimizes it under every operating condition, ensuring an energy efficiency level. The hermetically sealed electrical panel also guarantees greater reliability and safety. Thanks to the advanced management strategies that have been implemented, the control electronics integrate the functioning of the units' key components, thereby optimizing interaction between the main parts: compressor, fan, and water circulator.

R290 (propane) is a natural refrigerant. Its very low GWP value, equal to 3, makes it the optimal solution to help reduce the environmental impact of greenhouse gases and therefore global warming. Furthermore, due to its technical characteristics, it allows the working range of heat pumps to be expanded, allowing their use even in extreme and very harsh conditions, guaranteeing the production of high temperature water. We manage to guarantee an outlet water temperature of 50°C even with external temperatures of -25°C, reaching a maximum of 75°C starting from -10°C. Due to its flammability (class A3), particular attention must be paid to the characteristics of the installation site. The regulatory legislation EN 378 part 3 specifies the requirements to be respected for the safe management of the installation site.

### MAIN COMPONENTS



New controller with color screen, touch key design and intuitive interface that improves customer experience. The heat pump user terminal MLP is a sophisticated controller capable of extending the basic functions of the electronics on board the machine. In addition to managing the main functions, it also allows access to advanced programming levels.

Customized time slots and the possibility of implementing climate curves allow to modulate the operation of the machine and maximize the overall efficiency of the heating and air conditioning system. It allows the management of external equipment such as dehumidifiers, additional hydraulic circulators, three-way valves for the production of domestic hot water and boilers or other external backup devices. Easy to install thanks to a non-polarized wiring connection.

## EXTENDED OPERATING RANGE FOR EACH APPLICATION

MLP series heat pumps were designed to ensure maximum flexibility in every application. Thanks to their extremely wide operating range ensuring the operation even in particularly cold climates and allowing them to produce water up to a maximum of 75°C and to the advanced adjustment logics provided by the electronic control, they are able to ensure not only winter heating and summer air conditioning, but also the production of thermal energy to be used for domestic hot water production. Thanks to the use of propane, MLP is able to guarantee hot water at 55°C with an external temperature of -25°C, up to a maximum of 75°C with a minimum external temperature of -10°C

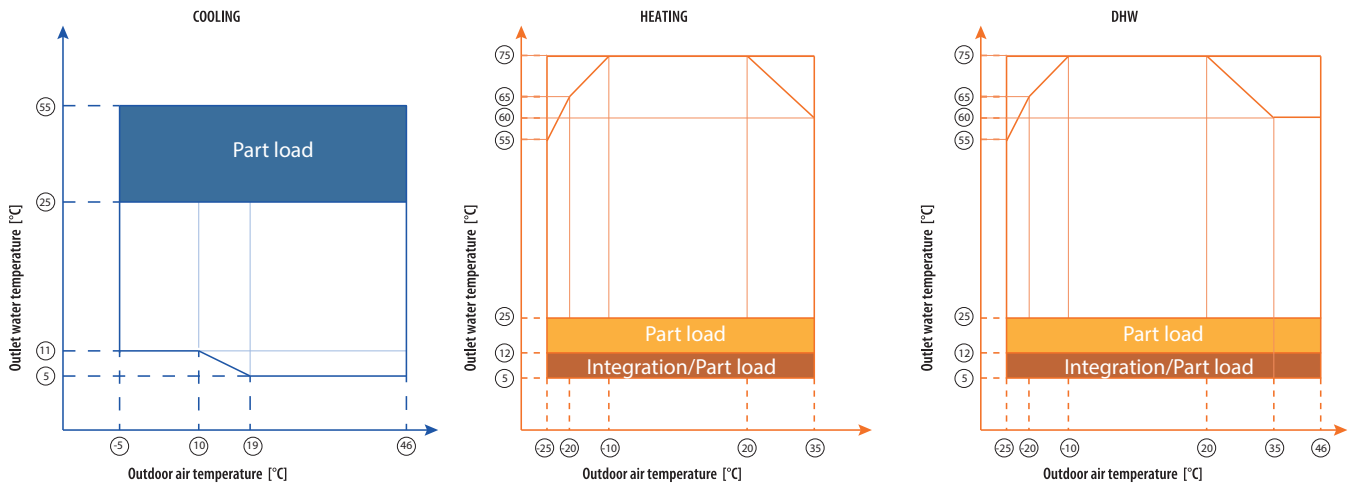

## INSTALLATION EXAMPLE

With MLP it is possible to connect up to 6 machines in cascade, and manage up to two different zones. At the same time it is possible to manage an external three-way valve for the management of domestic hot water production.

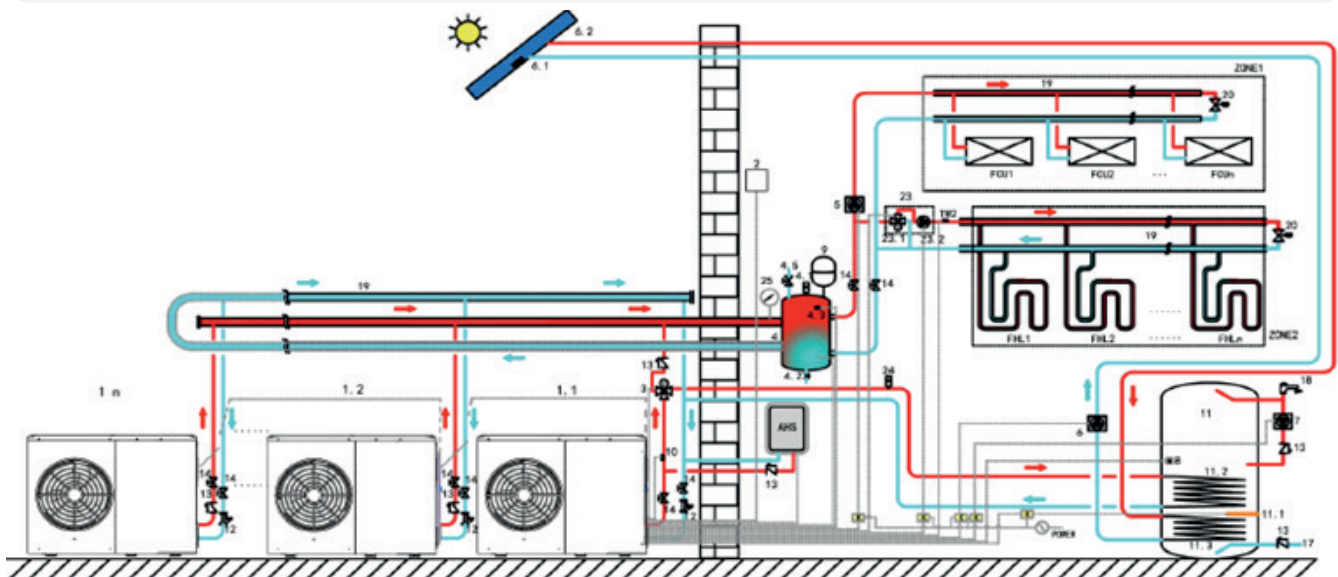

# Air heat pumps with natural refrigerant MLP

## RATED TECHNICAL DATA

MLP			006HM	008HM	010HM
Power supply		V-ph-Hz		230-1-50	
Cooling capacity	(1)(E)	kW	6,80	7,50	8,90
Total power input	(1)(E)	kW	2,19	2,17	2,74
EER	(1)(E)		3,10	3,45	3,25
SEER	(2)(E)		5,32	5,86	5,55
$\eta_{sc}$	(2)(E)		210	231	219
Water flow	(1)	l/h	1170	1290	1531
Available pressure head - LP pumps	(1)(E)	kPa	84	82	77
Heating capacity	(3)(E)	kW	6,40	8,20	10,0
Total power input	(3)(E)	kW	1,68	2,13	2,74
COP	(3)(E)		3,80	3,85	3,65
SCOP	(4)(E)		4,89	5,19	5,07
$\eta_{sh}$	(4)(E)		193	204	200
Heating energy efficiency class	(5)			A+++	
SCOP	(6)(E)		3,82	3,82	3,82
$\eta_{sh}$	(6)(E)		150	150	150
Heating energy efficiency class	(7)			A++	
Water flow	(3)	l/h	1101	1410	1720
Available pressure head - LP pumps	(3)(E)	kPa	85	80	70
Cooling capacity	(8)(E)	kW	6,50	8,30	10,0
Total power input	(8)(E)	kW	1,27	1,61	2,11
EER	(8)(E)		5,10	5,15	4,75
Heating capacity	(9)(E)	kW	6,20	8,40	10,0
Total power input	(9)(E)	kW	1,27	1,68	2,13
COP	(9)(E)		4,90	5,00	4,69
Maximum current absorption		A	15,0	19,0	19,0
Expansion vessel volume		dm <sup>3</sup>	8	8	8
Sound power level	(10)(E)	dB(A)	58	60	61
Operating weight - unit with pump		kg	90	117	117

(1) Outdoor air temperature 35°C, water temperature 12°C / 7°C (EN14511:2022)

(2)  $\eta$  efficiency values for heating and cooling are respectively calculated by the following formulas:  $[\eta = SCOP / 2,5 - F(1) - F(2)]$  e  $[\eta = SEER / 2,5 - F(1) - F(2)]$ . For further information, please refer to the technical document "ErP 2009/125/EC DIRECTIVE" in the catalogue introducing pages, or to the EN14825:2022 regulation.

(3) Outdoor air temperature dry bulb 7°C / wet bulb 6°C, water temperature 40°C / 45°C (EN14511:2022)

(4)  $\eta$  efficiency values for heating and cooling are respectively calculated by the following formulas:  $[\eta = SCOP / 2,5 - F(1) - F(2)]$  e  $[\eta = SEER / 2,5 - F(1) - F(2)]$ . For further information, please refer to the technical document "ErP 2009/125/EC DIRECTIVE" in the catalogue introducing pages, or to the EN14825:2022 regulation. Low temperature conditions.

(5) Seasonal energy efficiency class for LOW TEMPERATURE room heating under AVERAGE climatic conditions [EUROPEAN REGULATION No 811/2013]

(6)  $\eta$  efficiency values for heating and cooling are respectively calculated by the following formulas:  $[\eta = SCOP / 2,5 - F(1) - F(2)]$  e  $[\eta = SEER / 2,5 - F(1) - F(2)]$ . For further information, please refer to the technical document "ErP 2009/125/EC DIRECTIVE" in the catalogue introducing pages, or to the EN14825:2022 regulation. Medium temperature conditions.

(7) Seasonal energy efficiency class for MEDIUM TEMPERATURE room heating under AVERAGE climatic conditions [EUROPEAN REGULATION No 811/2013]

(8) Outdoor air temperature 35°C, water temperature 23°C / 18°C (EN14511:2022)

(9) Outdoor air temperature dry bulb 7°C / wet bulb 6°C, water temperature 30°C / 35°C (EN14511:2022)

(10) Sound power level measured according to ISO 9614

(E) EUROVENT certified data

**RATED TECHNICAL DATA**

MLP			012H0	012HM	016H0
Power supply		V-ph-Hz	400-3N-50	230-1-50	400-3N-50
Cooling capacity	(1)(E)	kW	11,5	11,5	14,0
Total power input	(1)(E)	kW	3,77	3,77	5,09
EER	(1)(E)		3,05	3,05	2,75
SEER	(2)(E)		5,19	5,19	5,12
$\eta_{sc}$	(2)(E)		204	204	202
Water flow	(1)	l/h	1978	1978	2408
Available pressure head - LP pumps	(1)(E)	kPa	64	64	49
Heating capacity	(3)(E)	kW	12,0	12,0	15,0
Total power input	(3)(E)	kW	3,24	3,24	4,48
COP	(3)(E)		3,70	3,70	3,35
SCOP	(4)(E)		4,67	4,67	4,59
$\eta_{sh}$	(4)(E)		184	184	181
Heating energy efficiency class	(5)			A+++	
SCOP	(6)(E)		3,62	3,62	3,57
$\eta_{sh}$	(6)(E)		142	142	140
Heating energy efficiency class	(7)			A++	
Water flow	(3)	l/h	2064	2064	2580
Available pressure head - LP pumps	(3)(E)	kPa	61	61	44
Cooling capacity	(8)(E)	kW	12,0	12,0	16,0
Total power input	(8)(E)	kW	2,67	2,67	4,10
EER	(8)(E)		4,50	4,50	3,90
Heating capacity	(9)(E)	kW	12,0	12,0	15,0
Total power input	(9)(E)	kW	2,50	2,50	3,41
COP	(9)(E)		4,80	4,80	4,40
Maximum current absorption		A	11,0	31,0	11,0
Expansion vessel volume		dm <sup>3</sup>	8	8	8
Sound power level	(10)(E)	dB(A)	65	65	69
Operating weight - unit with pump		kg	137	135	137

(1) Outdoor air temperature 35°C, water temperature 12°C / 7°C (EN14511:2022)

(2)  $\eta$  efficiency values for heating and cooling are respectively calculated by the following formulas: [ $\eta = SCOP / 2,5 - F(1) - F(2)$ ] e [ $\eta = SEER / 2,5 - F(1) - F(2)$ ]. For further information, please refer to the technical document "ErP 2009/125/EC DIRECTIVE" in the catalogue introducing pages, or to the EN14825:2022 regulation.

(3) Outdoor air temperature dry bulb 7°C / wet bulb 6°C, water temperature 40°C / 45°C (EN14511:2022)

(4)  $\eta$  efficiency values for heating and cooling are respectively calculated by the following formulas: [ $\eta = SCOP / 2,5 - F(1) - F(2)$ ] e [ $\eta = SEER / 2,5 - F(1) - F(2)$ ]. For further information, please refer to the technical document "ErP 2009/125/EC DIRECTIVE" in the catalogue introducing pages, or to the EN14825:2022 regulation. Low temperature conditions.

(5) Seasonal energy efficiency class for LOW TEMPERATURE room heating under AVERAGE climatic conditions [EUROPEAN REGULATION No 811/2013]

(6)  $\eta$  efficiency values for heating and cooling are respectively calculated by the following formulas: [ $\eta = SCOP / 2,5 - F(1) - F(2)$ ] e [ $\eta = SEER / 2,5 - F(1) - F(2)$ ]. For further information, please refer to the technical document "ErP 2009/125/EC DIRECTIVE" in the catalogue introducing pages, or to the EN14825:2022 regulation. Medium temperature conditions.

(7) Seasonal energy efficiency class for MEDIUM TEMPERATURE room heating under AVERAGE climatic conditions [EUROPEAN REGULATION No 811/2013]

(8) Outdoor air temperature 35°C, water temperature 23°C / 18°C (EN14511:2022)

(9) Outdoor air temperature dry bulb 7°C / wet bulb 6°C, water temperature 30°C / 35°C (EN14511:2022)

(10) Sound power level measured according to ISO 9614

(E) EUROVENT certified data

# Air heat pumps with natural refrigerant MLP

## RATED TECHNICAL DATA

MLP			016HM	026H0	030H0
Power supply		V-ph-Hz	230-1-50	400-3N-50	400-3N-50
Cooling capacity	(1)(E)	kW	14,0	26,0	30,0
Total power input	(1)(E)	kW	5,09	8,40	10,7
EER	(1)(E)		2,75	3,10	2,80
SEER	(2)(E)		5,12	5,21	4,99
$\eta_{sc}$	(2)(E)		202	205	197
Water flow	(1)	l/h	2408	4472	5160
Available pressure head - LP pumps	(1)(E)	kPa	49	71	54
Heating capacity	(3)(E)	kW	15,0	26,0	30,0
Total power input	(3)(E)	kW	4,48	6,82	8,26
COP	(3)(E)		3,35	3,81	3,63
SCOP	(4)(E)		4,59	4,95	4,92
$\eta_{sh}$	(4)(E)		181	195	194
Heating energy efficiency class	(5)			A+++	
SCOP	(6)(E)		3,57	3,84	3,79
$\eta_{sh}$	(6)(E)		140	151	149
Heating energy efficiency class	(7)		A++	A+++	A++
Water flow	(3)	l/h	2580	4472	5160
Available pressure head - LP pumps	(3)(E)	kPa	44	71	54
Cooling capacity	(8)(E)	kW	16,0	26,0	30,0
Total power input	(8)(E)	kW	4,10	5,60	6,80
EER	(8)(E)		3,90	4,64	4,41
Heating capacity	(9)(E)	kW	15,0	26,0	30,0
Total power input	(9)(E)	kW	3,41	5,45	6,67
COP	(9)(E)		4,40	4,77	4,50
Maximum current absorption		A	31,0	35,0	35,0
Expansion vessel volume		dm <sup>3</sup>	8	5	5
Sound power level	(10)(E)	dB(A)	69	69	74
Operating weight - unit with pump		kg	135	260	260

(1) Outdoor air temperature 35°C, water temperature 12°C / 7°C (EN14511:2022)

(2)  $\eta$  efficiency values for heating and cooling are respectively calculated by the following formulas:  $[\eta = SCOP / 2,5 - F(1) - F(2)]$  e  $[\eta = SEER / 2,5 - F(1) - F(2)]$ . For further information, please refer to the technical document "ErP 2009/125/EC DIRECTIVE" in the catalogue introducing pages, or to the EN14825:2022 regulation.

(3) Outdoor air temperature dry bulb 7°C / wet bulb 6°C, water temperature 40°C / 45°C (EN14511:2022)

(4)  $\eta$  efficiency values for heating and cooling are respectively calculated by the following formulas:  $[\eta = SCOP / 2,5 - F(1) - F(2)]$  e  $[\eta = SEER / 2,5 - F(1) - F(2)]$ . For further information, please refer to the technical document "ErP 2009/125/EC DIRECTIVE" in the catalogue introducing pages, or to the EN14825:2022 regulation. Low temperature conditions.

(5) Seasonal energy efficiency class for LOW TEMPERATURE room heating under AVERAGE climatic conditions [EUROPEAN REGULATION No 811/2013]

(6)  $\eta$  efficiency values for heating and cooling are respectively calculated by the following formulas:  $[\eta = SCOP / 2,5 - F(1) - F(2)]$  e  $[\eta = SEER / 2,5 - F(1) - F(2)]$ . For further information, please refer to the technical document "ErP 2009/125/EC DIRECTIVE" in the catalogue introducing pages, or to the EN14825:2022 regulation. Medium temperature conditions.

(7) Seasonal energy efficiency class for MEDIUM TEMPERATURE room heating under AVERAGE climatic conditions [EUROPEAN REGULATION No 811/2013]

(8) Outdoor air temperature 35°C, water temperature 23°C / 18°C (EN14511:2022)

(9) Outdoor air temperature dry bulb 7°C / wet bulb 6°C, water temperature 30°C / 35°C (EN14511:2022)

(10) Sound power level measured according to ISO 9614

(E) EUROVENT certified data

DIMENSIONAL DRAWINGS

MLP 006

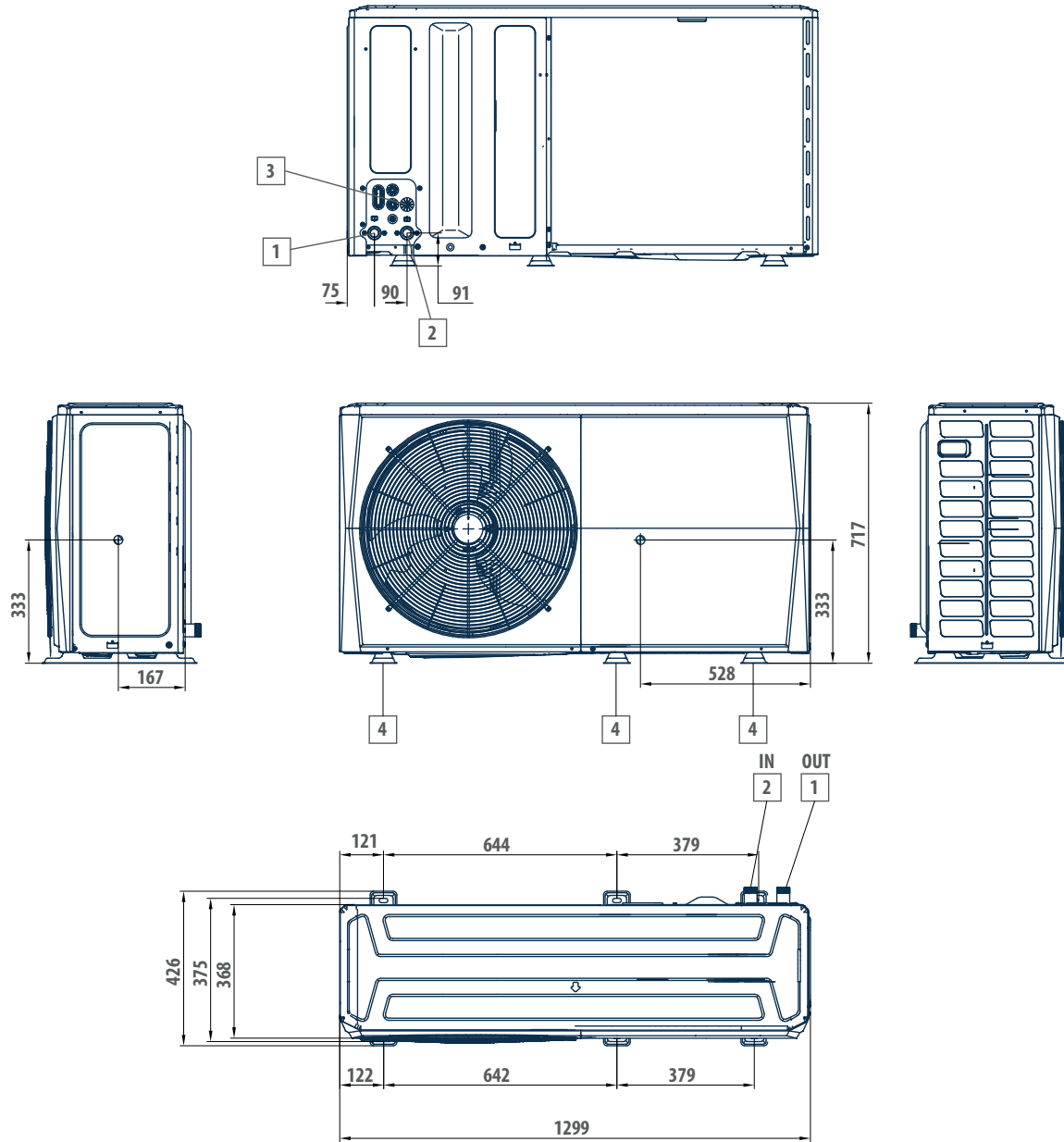

**LEGEND**

- |   |                             |
|---|-----------------------------|
| 1 | Water outlet user 1"        |
| 2 | Water inlet on user side 1" |
| 3 | Outlet safety valve 16 mm   |
| 4 | Vibration dampers           |

Air heat pumps with natural refrigerant - MLP

# Air heat pumps with natural refrigerant MLP

## DIMENSIONAL DRAWINGS

MLP 008-016

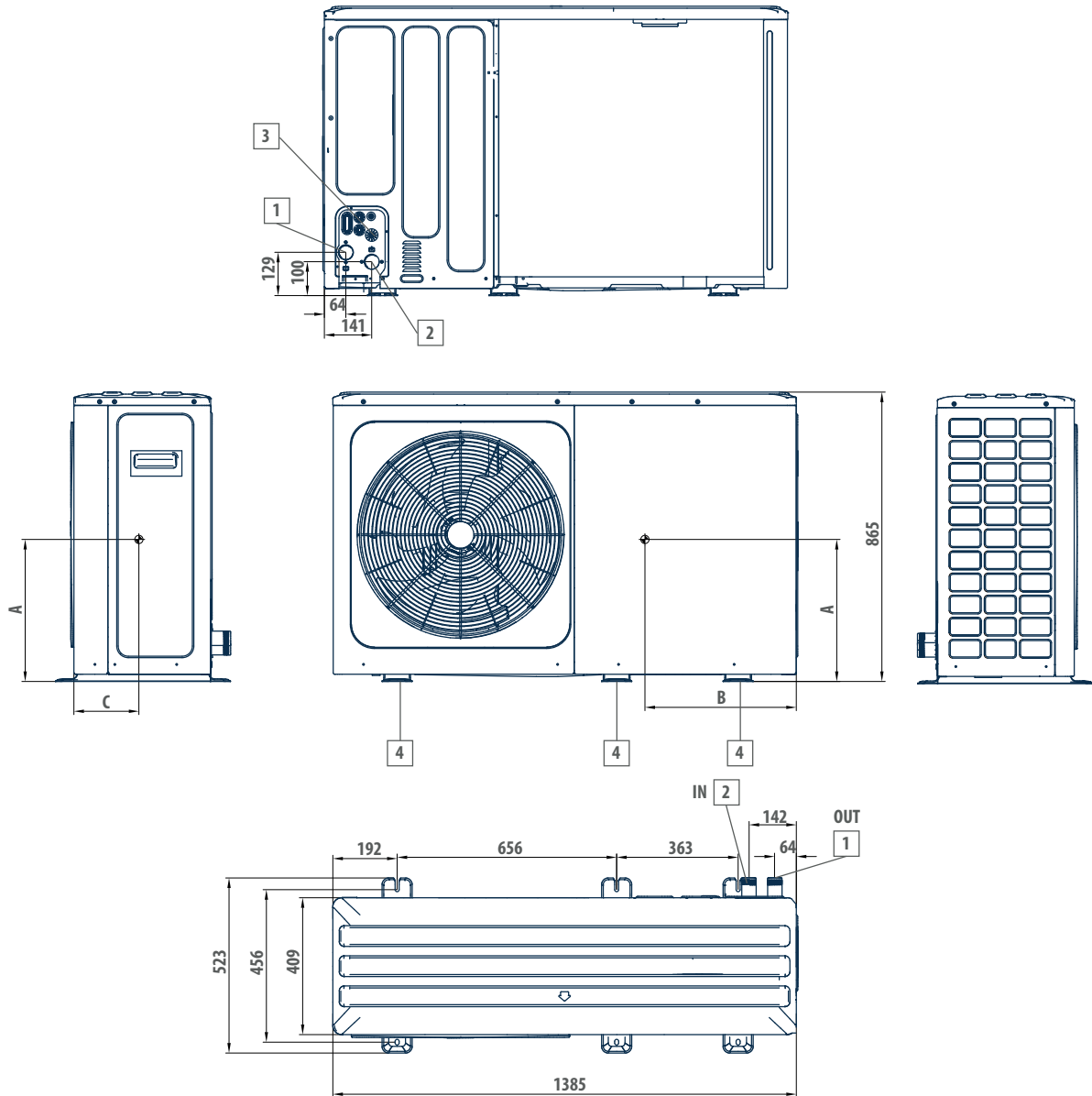

### LEGEND

- 1 Water outlet user 1 1/4"
- 2 Water inlet on user side 1 1/4"
- 3 Outlet safety valve 16 mm
- 4 Vibration dampers

Mod.	A mm	B mm	C mm
MLP008HM	360	550	234
MLP010HM	360	550	234
MLP012HM	415	715	200
MLP012H0	415	715	200
MLP016HM	415	715	200
MLP016H0	415	715	200

DIMENSIONAL DRAWINGS

MLP 026-030

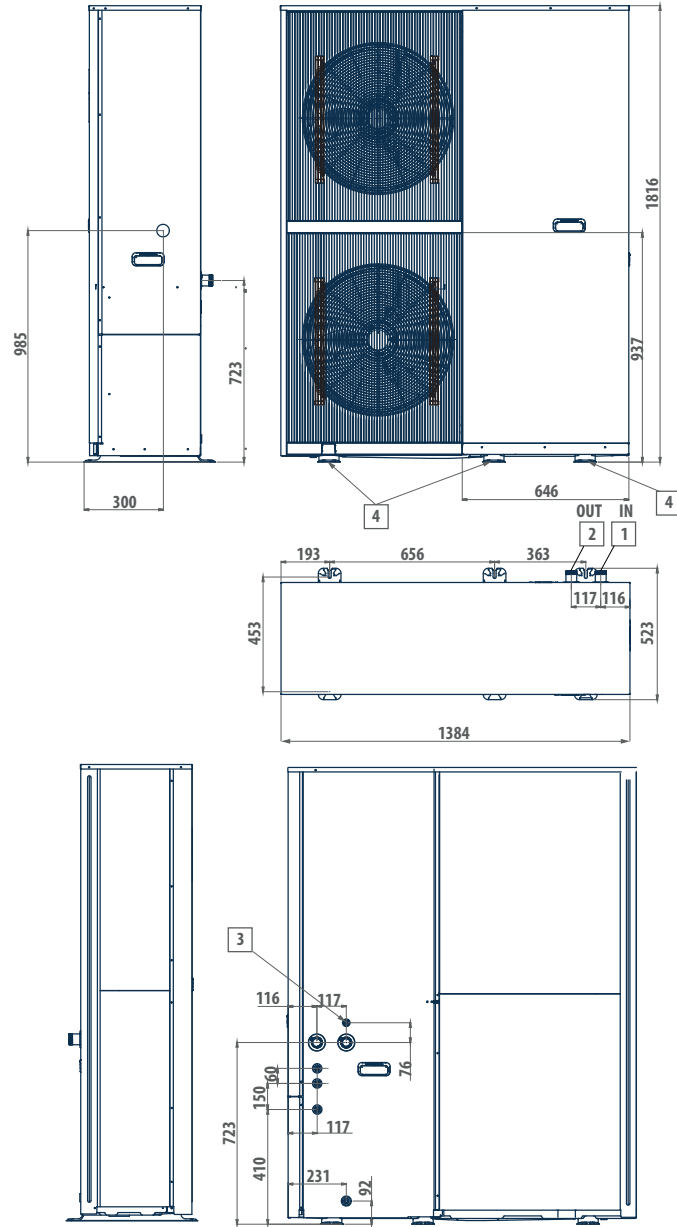

**LEGEND**

- |   |                                 |
|---|---------------------------------|
| 1 | Water outlet user 1 1/4"        |
| 2 | Water inlet on user side 1 1/4" |
| 3 | Outlet safety valve 16 mm       |
| 4 | Vibration dampers               |