

Indoor or outdoor packaged unit

WBE 45 - 220 kW



Refrigerant R-515B



Scroll compressor



Heating only

PLUS

- » Refrigerant R515B (GWP=293)
- » Refrigerant R515B A1 class (non-flammable)
- » Up to 4 compressors
- » Remote connectivity with the most common protocols
- » Compact dimensions
- » Three different acoustic configurations
- » High seasonal efficiency values
- » Production of water up to 90°C
- » Minimum source-side water temperature of 5°C

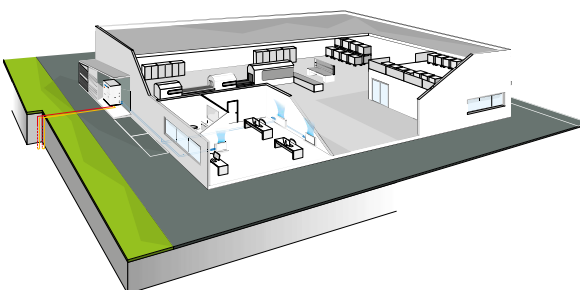

Booster unit for high-temperature water production. Indoor or outdoor installation, featuring high seasonal efficiency with a non-flammable, low GWP refrigerant.

WBE is the new Galletti series of non-reversible water-cooled heat pumps for high-temperature water production. The new Galletti booster is capable of working with low or medium-temperature sources.

WBE can be installed both outdoors and indoors.

The use of R515B refrigerant allows for the combination of safety and environmental respect. R515B is an A1 refrigerant, therefore non-flammable, which at the same time features one of the lowest GWPs on the market, equal to only 293.

These characteristics ensure the WBE range complies with the gradual reduction of emissions due to the use of greenhouse gases imposed by F-GAS regulations, while simultaneously facilitating installation thanks to its non-flammability.

The range covers a power range starting from 45 kW up to a maximum of 220 kW, and is characterized by high levels of seasonal efficiency and reduced footprints to facilitate access to technical rooms.

The use of top quality components at the cutting edge of technology in the cooling, hydraulic, and electrical systems makes WBE state of the art in terms of efficiency, reliability, and operating limits.

The WBE range is designed to produce high-temperature water, up to 90 °C, evaporating on a medium-temperature thermal source (typically at 45 °C), making it ideal for cascade use with air-cooled heat pumps. Furthermore, thanks to the wide operating range on the source side, it can operate even with very low temperatures, down to 5 °C, independently guaranteeing the entire thermal lift required by the system.

The high configurability of the series, inherent to Galletti's DNA, is guaranteed by 2 different construction versions, with and without closing panels, and 3 different acoustic setups: standard, low-noise, and super low-noise, capable of ensuring a reduction in sound power level of up to 6 dB(A).

The advanced microprocessor that regulates the unit's operation finally allows for the control of a maximum of 2 user-side pumps and 2 source-side pumps, either on/off or modulating.

EXTENDED OPERATING RANGE FOR EACH APPLICATION

With Galletti WBE allows for the selection of a 'low source-side temperature' option, extending the operating envelope for applications with lower source temperatures.

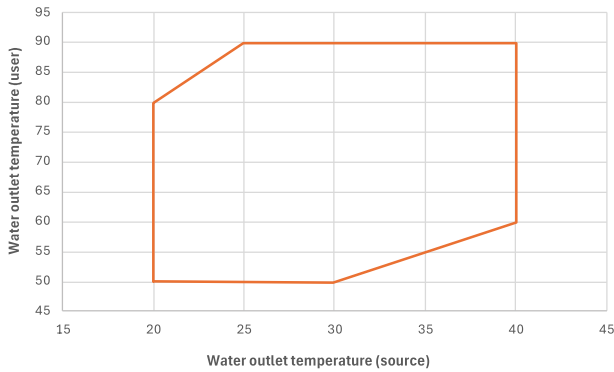
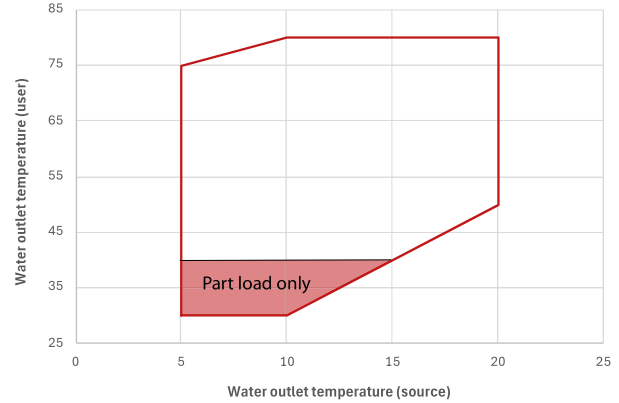
High source T operating range

Low source T operating range

CONFIGURATOR

The models are completely configurable by selecting the version and the options. To the right is shown an example of configuration.

Version	Field	1	2	3	4	5	6	7	8	9	10
WBE		2	B	0	1	1	0	0	0	0	0

To verify the compatibility of the options, use the selection software or the price list.

AVAILABLE VERSIONS

WBE...VVS
WBE...VVL
WBE...VVQ

Heating only, standard execution
Heating only, low noise execution
Heating only, super low noise execution

CONFIGURATION OPTIONS

- 1 Power supply**
 - 2 400/3/50 + N + Circuit breakers
 - 5 400/3/50 + circuit breakers
- 2 Control microprocessor and lamination device**
 - B Advanced + Electronic expansion valve
 - X Advanced + electronic expansion valve for source side low temperature
- 3 Partial heat recovery**
 - 0 Absent
- 4 Source water flow modulation**
 - 1 Single pump
 - 2 Dual pump
 - 3 Single pump + condensation control with 0-10V modulated output signal
 - 4 Dual pump + condensation control with 0-10V modulated output signal
- 5 User water flow modulation**
 - 1 Single pump
 - 2 Dual pump
 - 3 Single pump + output signal with water flow modulation in ΔT logic = cost
 - 4 Dual pump + output signal with water flow modulation in ΔT logic = cost
 - 5 Single pump + output signal with water flow modulation in T logic = cost
 - 6 Dual pump + output signal with water flow modulation in T logic = cost

- 6 Remote communication**
 - 0 Absent
 - 1 RS485 serial board (Carel / Modbus protocol)
 - 4 Ethernet card (SNMP or BACNET protocol)
 - 5 Ethernet card + monitoring software
- 7 Anti vibration shock mounts**
 - 0 Absent
 - G Made of rubber
 - M With spring
- 8 Packing**
 - 0 Absent
 - 1 Wooden cage
 - 2 Wooden crate
- 9 Remote control**
 - 0 Absent
 - 1 Remote simplified control panel
 - 3 Remote display for programmable microprocessor
- 10 Anti-intrusion panelling**
 - 0 Absent
 - P Present (standard for Q version)

ACCESSORIES

A	Power factor capacitors	L	Filter regulating kit (supplied)
B	Soft starter	M	Set point compensation outdoor temperature probe (supplied)
C	Smart Grid Certification	N	Compressor tandem/trio isolation valves
E	ON/OFF status of the compressors	P	Unit lifting pipes
F	Remote free contact for capacity limitation	Q	Temperature probe for pump shutdown on the primary circuit
G	Configurable digital alarm card	T	Mains power analyzer for monitoring and reducing power consumption
H	Refrigerant pressure gauges	V	Set-point modification with 4-20mA signal
I	Two pairs of Victaulic joints	4	2 Dirt separators (supplied as an accessory)

High-temperature non-reversible heat pump with Low GWP Refrigerant WBE

WBE HEAT PUMPS RATED TECHNICAL DATA

WBE			051	061	082	092	122
Power supply		V-ph-Hz	400/3/50				
Heating capacity	(1)	kW	47,0	56,5	78,3	92,9	114
Total power input	(1)	kW	10,3	12,7	17,8	20,3	25,4
COP	(1)		4,58	4,46	4,39	4,57	4,51
SCOP	(2)		4,05	3,80	4,31	4,35	4,00
Heating energy efficiency class	(3)		A+++				
Water flow user side	(1)	l/h	5170	6217	8620	10221	12592
Water pressure drop user side	(1)	kPa	20	35	24	25	25
Water flow source side	(1)	l/h	6468	7725	10667	12784	15693
Water pressure drop source side	(1)	kPa	31	57	31	41	50
Maximum current absorption		A	29,0	35,0	49,0	59,0	69,0
Start up current		A	156	174	135	185	209
Startup current with soft starter		A	94	104	91	123	139
no. of compressors / circuits			1/1	1/1	2/1	2/1	2/1
Sound power level	(4)	dB(A)	79	80	81	81	82
Height		mm	1034	1034	1034	1034	1957
Length		mm	1817	1817	1817	1817	1813
Depth		mm	799	799	799	799	799
Maximum transport weight		kg	308	313	393	400	620

(1) Water temperature - user side 70/78 °C, water temperature - source side 40 °C / 45 °C (EN14511:2022)

(2) η efficiency values for heating and cooling are respectively calculated by the following formulas: $[\eta = SCOP / 2,5 - F(1) - F(2)]$ e $[\eta = SEER / 2,5 - F(1) - F(2)]$. For further information, please refer to the technical document "ErP 2009/125/EC DIRECTIVE" in the catalogue introducing pages, or to the EN14825:2022 regulation. Medium temperature conditions.

(3) Seasonal energy efficiency class for MEDIUM TEMPERATURE room heating under AVERAGE climatic conditions [EUROPEAN REGULATION No 811/2013]

(4) Sound power level measured according to ISO 9614

WBE			164	184	194	224
Power supply		V-ph-Hz	400/3/50			
Heating capacity	(1)	kW	155	175	186	217
Total power input	(1)	kW	35,4	38,7	40,8	51,3
COP	(1)		4,37	4,52	4,55	4,23
SCOP	(2)		4,33	4,26	4,54	3,94
Heating energy efficiency class	(3)		A+++			
Water flow user side	(1)	l/h	17019	19242	20441	23868
Water pressure drop user side	(1)	kPa	15	17	19	19
Water flow source side	(1)	l/h	21025	23992	25542	29223
Water pressure drop source side	(1)	kPa	26	34	38	37
Maximum current absorption		A	99,0	109	117	139
Start up current		A	184	206	244	278
Startup current with soft starter		A	140	156	182	209
no. of compressors / circuits			4/2			
Sound power level	(4)	dB(A)	84	84	84	85
Height		mm	1957	1957	1957	1957
Length		mm	2265	2265	2265	2265
Depth		mm	799	799	799	799
Maximum transport weight		kg	905	929	938	1010

(1) Water temperature - user side 70/78 °C, water temperature - source side 40 °C / 45 °C (EN14511:2022)

(2) η efficiency values for heating and cooling are respectively calculated by the following formulas: $[\eta = SCOP / 2,5 - F(1) - F(2)]$ e $[\eta = SEER / 2,5 - F(1) - F(2)]$. For further information, please refer to the technical document "ErP 2009/125/EC DIRECTIVE" in the catalogue introducing pages, or to the EN14825:2022 regulation. Medium temperature conditions.

(3) Seasonal energy efficiency class for MEDIUM TEMPERATURE room heating under AVERAGE climatic conditions [EUROPEAN REGULATION No 811/2013]

(4) Sound power level measured according to ISO 9614

DIMENSIONAL DRAWINGS

WBE 051-061-082-092

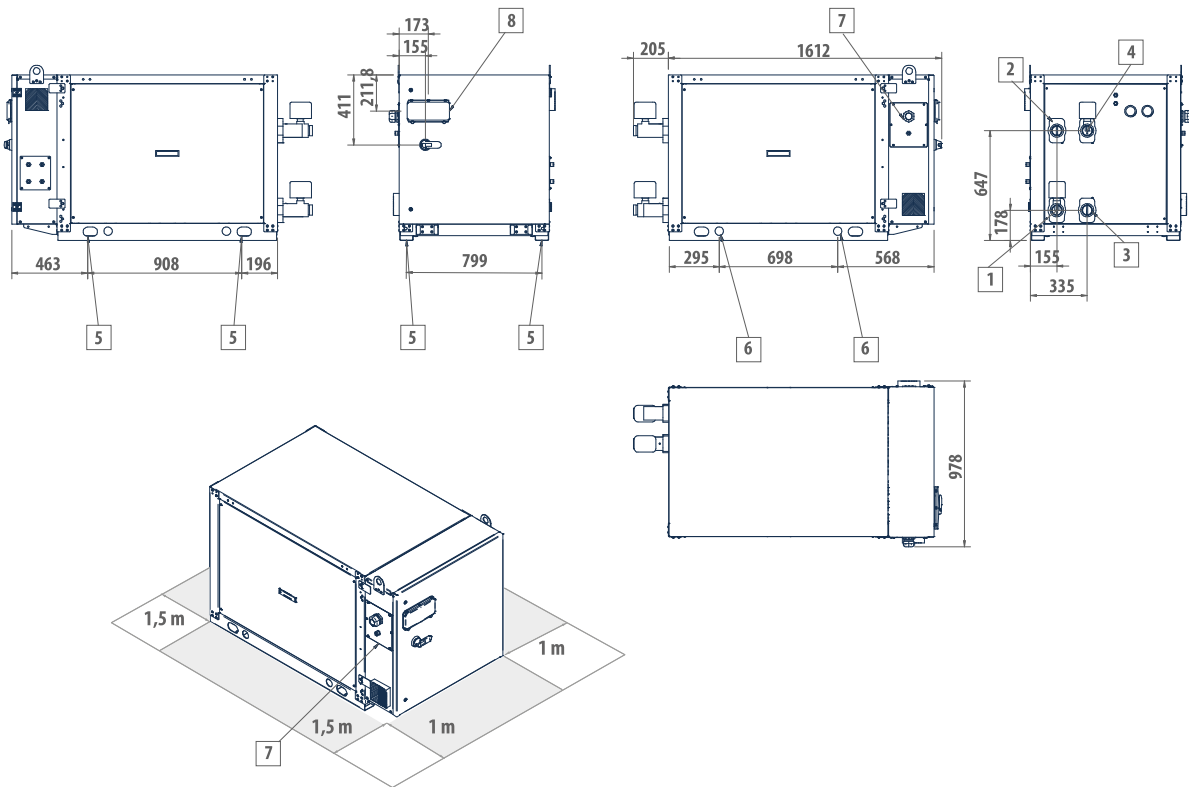

LEGEND

1	User side water inlet 2" Victaulic
2	User side water outlet 2" Victaulic
3	Source side water outlet 2" Victaulic
4	Source side water inlet 2" Victaulic
5	Vibration dampers
6	Lifting points
7	Power supply input
8	User interface

Closing panelling available on request

For maintenance requirements, keep at least 0.5 m of clearance from the ceiling.

DIMENSIONAL DRAWINGS

WBE 122

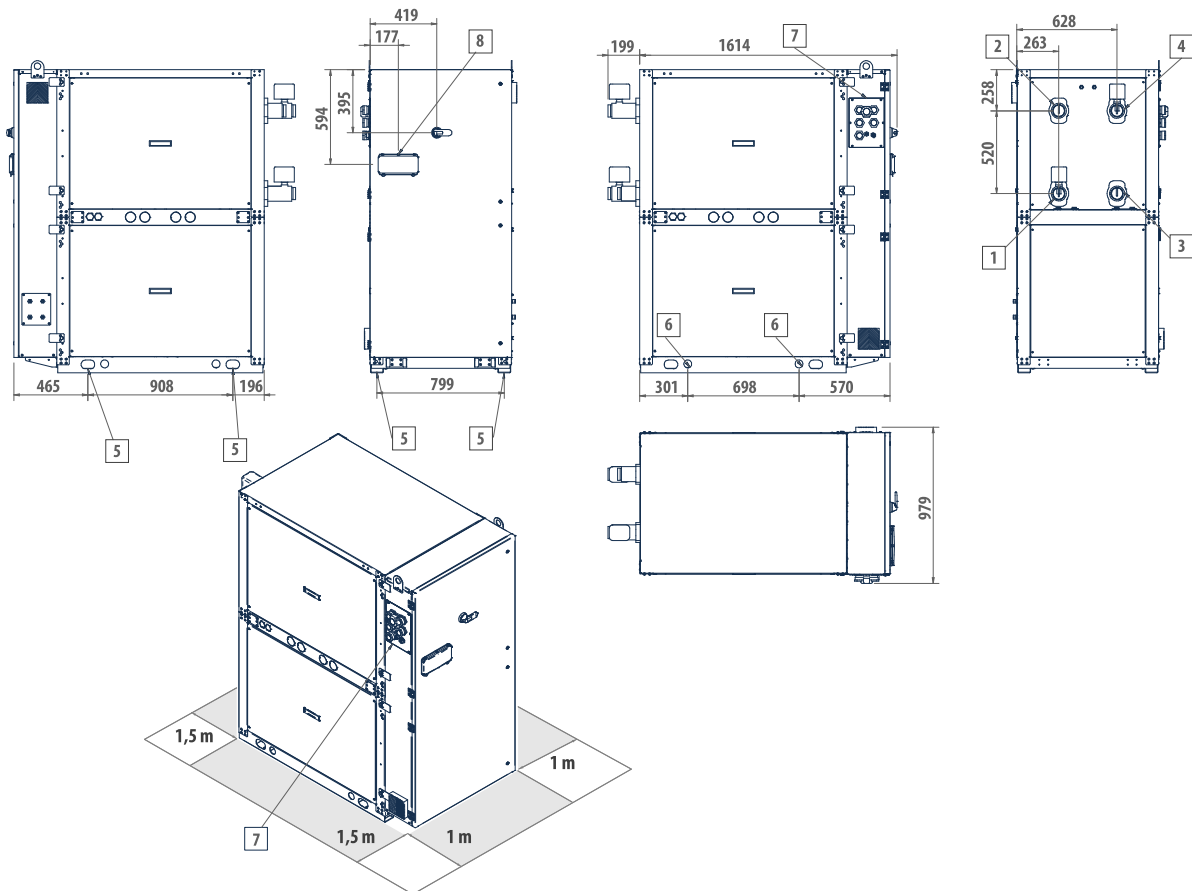

LEGEND

- | | |
|---|---|
| 1 | User side water inlet 2 1/2" Victaulic |
| 2 | User side water outlet 2 1/2" Victaulic |
| 3 | Source side water outlet 2 1/2" Victaulic |
| 4 | Source side water inlet 2 1/2" Victaulic |
| 5 | Vibration dampers |
| 6 | Lifting points |
| 7 | Power supply input |
| 8 | User interface |

Closing panelling available on request

For maintenance requirements, keep at least 0.5 m of clearance from the ceiling.

DIMENSIONAL DRAWINGS

WBE 164 - 184 - 194 - 224

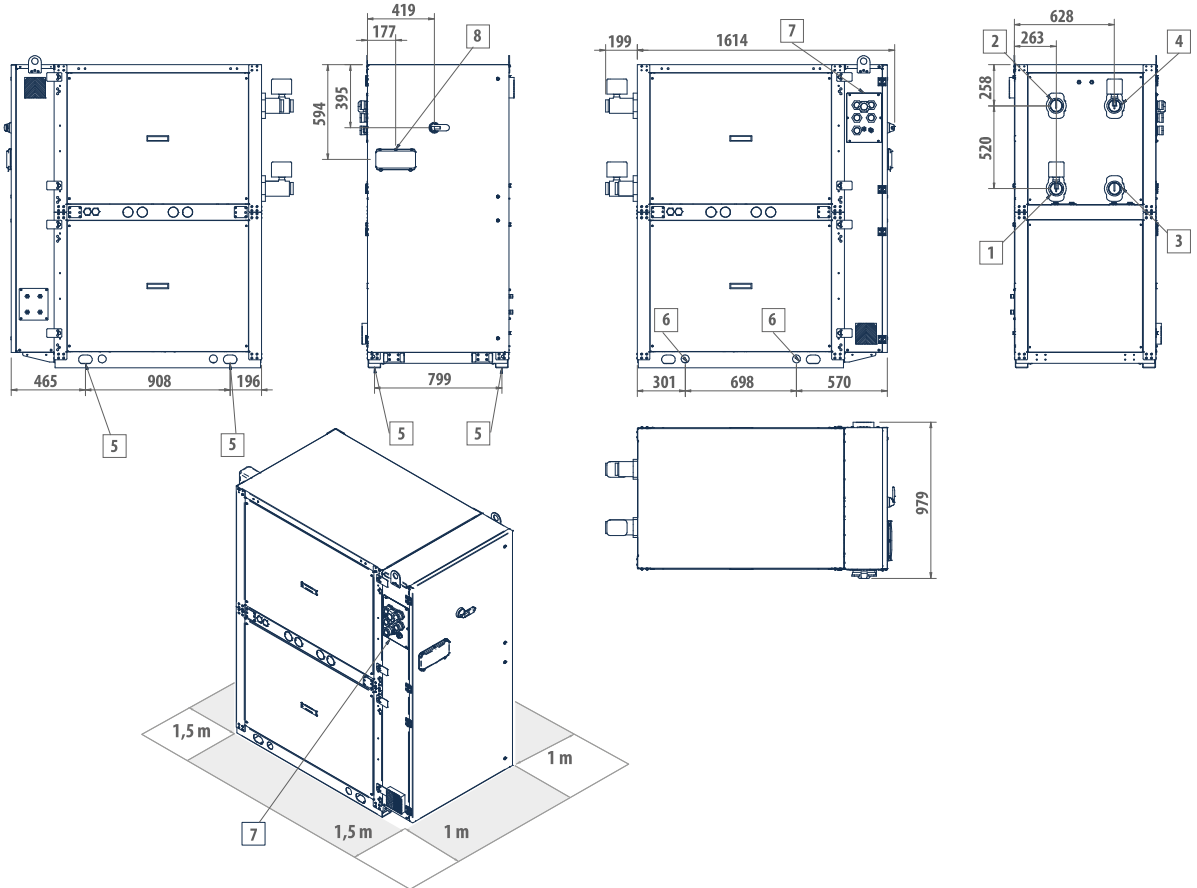

LEGEND

1	User side water inlet 2" 1/2 Victaulic WBE164W - WBE184W - WBE194W / 3" Victaulic WBE224W
2	User side water outlet 2" 1/2 Victaulic WBE164W - WBE184W - WBE194W / 3" Victaulic WBE224W
3	Source side water inlet 2" 1/2 Victaulic WBE164W - WBE184W - WBE194W / 3" Victaulic WBE224W
4	Source side water outlet 2" 1/2 Victaulic WBE164W - WBE184W - WBE194W / 3" Victaulic WBE224W
5	Vibration dampers
6	Lifting points
7	Power supply input
8	User interface

Closing panelling available on request

For maintenance requirements, keep at least 0.5 m of clearance from the ceiling.