

VLS Chillers and HP with Low GWP refrigerant



Outdoor packaged unit

VLS 160 - 590 kW



R-454B
refrigerant



Plate
exchanger



Piping shell
and tube heat
exchanger



Axial fan



Scroll
compressor



Cooling only



Heating/
Cooling

PLUS

- » Refrigerant with GWP of less than 500
- » Available version with R410A refrigerant (VRS)
- » High seasonal efficiency values
- » Electronic expansion valve
- » Up to 6 compressors
- » 1 or 2 cooling circuits
- » Remote connectivity with the most common protocols
- » Possibility to configure low-noise versions
- » Available version with shell and tube heat exchanger

VLS heat pumps and water chillers are designed for heating or cooling the water to be used in air-conditioning systems for residential, commercial, or industrial use.

The use of low-GWP refrigerant ensures compliance with the limits established by the F-GAS regulation regarding gases that potentially contribute to global warming (greenhouse gases).

Air-water unit with high seasonal efficiency and low-GWP refrigerant

VLS is Galletti's new range of air-cooled monobloc chillers and heat pumps for outdoor installation featuring R454B refrigerant. R454B is a next generation A2L refrigerant with a GWP of only 467, one of the lowest on the market. This GWP value ensures that the VLS range complies with the gradual reduction of greenhouse gas emissions required by the F-GAS regulation, down to the stricter limits foreseen for 2030.

The range consists of 12 models with cooling capacities ranging from 160 to 590 kW, available in cooling only or reversible heat pump versions. The range's main strength is its high seasonal efficiency, which is designed to permanently reduce annual energy consumption as well as meet the minimum efficiency requirements established by ErP 2021. In order to increase the efficiency at partial loads, all VLS models are provided with tandem or trio solutions (2 or 3 compressors on a single circuit) and equipped with electronic expansion valve as standard.

The use of top quality components at the cutting edge of technology in the cooling, hydraulic, and electrical systems makes VLS units chillers state of the art in terms of efficiency, reliability, and operating limits.

In fact, the ability to produce water from -10 °C to 56 °C and operate at full load with outdoor air temperatures from -15 °C to 46 °C is guaranteed. The range allows high configurability from an acoustic point of view, having a wide range of accessories designed to reduce noise emissions. It is also guaranteed the possibility of selecting the execution with shell and tube heat exchanger for all models above 200 kW. The advanced control, always present in the whole range, allows a continuous monitoring of the operating parameters, advanced adjustment logics, and connectivity.



CONFIGURATOR

The models are completely configurable by selecting the version and the options. To the right is shown an example of configuration.

| Version | Field | 1 | 2 | 3 | 4 | 5 | 6 | 7 | 8 | 9 | 10 | 11 | 12 | 13 |
|------------|-------|---|---|---|---|---|---|---|---|---|----|----|----|----|
| VLS162HS0B | | A | 1 | S | 0 | E | 0 | 0 | M | 0 | 0 | G | 0 | 1 |

To verify the compatibility of the options, use the selection software or the price list.

AVAILABLE VERSIONS

Only cooling versions and plate heat exchanger

- VLS..CS0B** Power supply 400V-3N-50Hz
- VLS..CS2B** Power supply 400V-3N-50Hz + circuit breaker
- VLS..CS4B** Power supply 400V-3-50Hz
- VLS..CS5B** Power supply 400V-3-50Hz + circuit breaker

Only cooling versions and shell and tube heat exchanger

- VLS..CT0B** Power supply 400V-3N-50Hz
- VLS..CT2B** Power supply 400V-3N-50Hz + circuit breaker
- VLS..CT4B** Power supply 400V-3-50Hz
- VLS..CT5B** Power supply 400V-3-50Hz + circuit breaker

Reversible heat pump versions and plate heat exchanger

- VLS..HS0B** Power supply 400V-3N-50Hz
- VLS..HS2B** Power supply 400V-3N-50Hz + circuit breaker
- VLS..HS4B** Power supply 400V-3-50Hz
- VLS..HS5B** Power supply 400V-3-50Hz + circuit breaker

Reversible heat pump versions and shell and tube heat exchanger

- VLS..HT0B** Power supply 400V-3N-50Hz
- VLS..HT2B** Power supply 400V-3N-50Hz + circuit breaker
- VLS..HT4B** Power supply 400V-3-50Hz
- VLS..HT5B** Power supply 400V-3-50Hz + circuit breaker

CONFIGURATION OPTIONS

1 Expansion valve

- A Electronic

2 Water pump and accessories

- 0 Absent
- 1 LP pump
- 2 LP OR double pump
- 3 HP pump
- 4 HP OR double pump
- 5 LP pump with Viton seal
- 6 LP OR double pump with Viton seal
- 7 HP pump with Viton seal
- 8 HP OR double pump with Viton seal
- A LP inverter pump
- B LP OR inverter double pump
- C HP Inverter pump
- D HP OR inverter double pump
- E LP inverter pump with Viton seal
- F LP inverter double pump with Viton seal
- G HP inverter pump with Viton seal

3 Water buffer tank

- 0 Absent
- S Present

4 Partial heat recovery

- 0 Absent
- D Included with pump free contact

5 Air flow modulation

- A Condensation control with high-head EC fans
- C Condensation control by phase-cut fans
- E Condensation control with EC fans

6 Antifreezing kit

- 0 Absent
- E Evaporator
- P Evaporator, pump and expansion vessel
- S Evaporator, pump, expansion vessel and tank

7 Acoustic insulation and attenuation

- 0 Absent
- 3 Insulation with compressor box and insulating mat + compressor sound jackets
- 6 Insulation with compressor box and insulating mat + compressor sound jackets + low noise EC fans (option "E" required in field 5)

8 Refrigerant pipework accessories

- 0 Absent
- 1 Liquid separator at compressor intake (heat pump only). Mandatory on 456,546,576 models.
- 2 Liquid separator in compressor intake + liquid injection for operation limit extension (only for heat pumps)

9 Remote control / Serial communication

- 0 Absent
- 2 RS485 connection port (Modbus protocol or Carel)
- B BACNET IP/pCOWeb serial board
- G BACNET IP / pCOWeb serial board + supervision software
- S Remote simplified control panel
- X mProcess remote control panel

10 Special coils / Protective treatments

- 0 Copper-aluminium (heat pump only)
- C Cataphoresis treatment on fins and coil carpentry
- E Microchannel in Long Life Alloy (standard for chiller)
- I Hydrophilic (heat pump only)
- M Microchannel with E-coating (standard for chiller)
- P Pre-painted fins with polyester paint (only heat pump)
- R Copper-copper (heat pump only)

11 Anti vibration shock mounts

- 0 Absent
- G Made of rubber
- M With spring

12 Outdoor coil trace heater

- 0 Absent
- 1 Present (heat pump only)

13 Onboard controller

- 1 Advanced

14 Protections

- 0 Absent
- G Anti-intrusion grilles (not available if cfg 7 = 3 or 6)
- Z Refrigerant circuit paneling (not available if cfg 7 = 3 or 6)

15 Language

- I Italian
- S Spanish
- E English
- F French
- D German

ACCESSORIES

| | | | |
|----------|---|----------|---|
| A | Outdoor finned coil heat exchanger protection filters | M | 0-10 V signal for external user pump control (on-board pump excluded) |
| B | Not in use | N | Compressor tandem/trio isolation valves |
| C | Pair of couplings Victaulic | O | Not in use |
| D | ON/OFF status of the compressors | P | Y-shaped filter |
| E | Remote control for step capacity limit (advanced controller required) | Q | Night-time low-noise |
| F | Configurable digital alarm board (advanced controller required) | R | Enabling 2nd set-point / external alarm signaling via digital input |
| G | Soft starter | S | Hot-wire electronic flow switch |
| H | Power factor capacitors | T | Energy metering kit |
| I | Refrigerant leak sensors (mandatory if cfg 7 = 3 or 6 or cfg 14 = Z) | U | Covering panels V |
| L | Water pipes additional insulation | V | Set-point modification with 4-20mA signal |

EXTENDED OPERATING RANGE

The generous sizing of the coils combined with innovative technological solutions makes it possible for VLS to operate in very different climat-ic environments. The operating range may vary depending on the model; always refer to the technical documentation for more information.

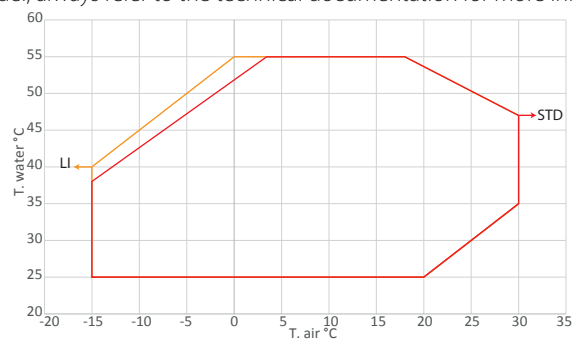
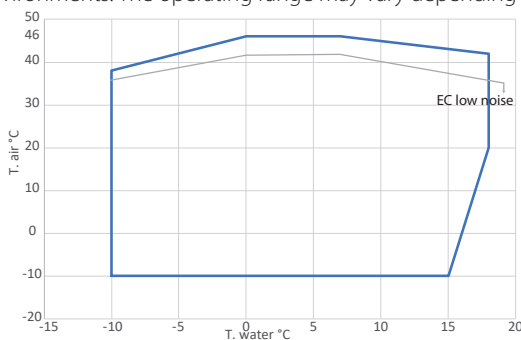

VLS Chillers and HP with Low GWP refrigerant

FUNCTIONS

Very low GWP refrigerant

Use of R454B refrigerant with low environmental impact. R454B is a next-generation A2L refrigerant with a GWP of only 467, one of the lowest on the market. This GWP value ensures that the VLS range complies with the gradual reduction of quotas of greenhouse refrigerants in the European market required by the F-GAS regulation, down to the stricter limits foreseen for 2030

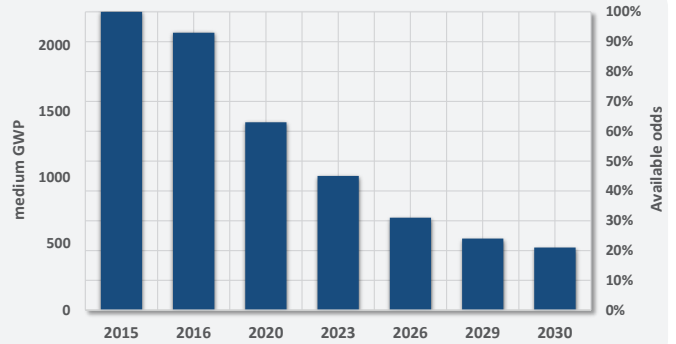

Scroll compressors

The scroll-type compressors designed to work with R454B, which can be sound insulated, include internal thermal protection of the windings and are installed on special anti-vibration supports. The scroll-type compressors are equipped with an IDV valve. The IDV intermediate delivery valve technology allows the compressor to avoid losses caused by overcompression and, consequently, the additional work the motor has to perform in partial-load operation, thus saving energy and improving seasonal and partial-load efficiency from 3% to 10%.



Liquid injection

Units can be supplied with a hot liquid by-pass to stabilise the discharge temperature of the compressor under the most critical operating conditions. Thanks to the injection of hot liquid at the evaporator outlet, it is possible to raise the evaporation pressure, thereby ensuring that the duty point remains within the compressor envelope even beyond conventional limits; in fact, hot water production up to 56°C is guaranteed.

To prevent liquid intake, this option includes a liquid/gas separator installed on the common branch before the tandem or trio compressor systems.

Microchannel

The entire Chiller range has microchannel coils as a standard feature. The large heat exchange surface, the absence of a copper-aluminum interface, and the perfect flow of air make it possible to achieve the same performance while reducing the refrigerant charge by up to 40%, with obvious benefits from an ecological point of view. Microchannel coils Galletti always feature surface treatment as a standard feature in order to provide maximum safety, even in harsh environments.

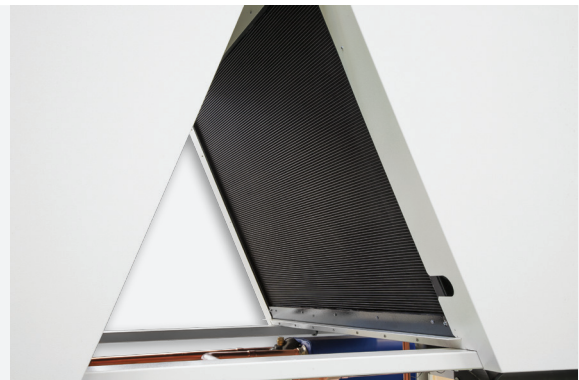

MAIN COMPONENTS

Structure

The range is designed modularly, replicating the optimized structure of V configuration condensing coils and fans. Its design ensures stability, sturdiness even during the most critical phases (such as transportation), and maximum accessibility to components in every VLS unit.



Electronic valve

It is standard on the entire range and offers greater responsiveness during transients. The electronics also manage the synergistic operation of the compressors and the valve, thereby making it possible to vary overheating and maximize efficiency at partial loads.



Safety procedures in case of refrigerant leakage

As an option feature, the units are equipped with leak detection sensors in the electrical control board and near the cooling circuit. The microprocessor manages the procedures for securing and shutting down the unit in case of refrigerant leakage, also making it possible to divert the power supply of the control unit that collects the information from the leak sensors on a low-voltage emergency line. This function allows the complete disconnection of the power to the unit during maintenance operations, while leaving all the safety systems enabled.

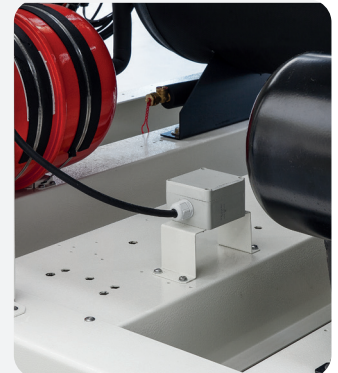

Economy - low noise function

Based on time slots or no-voltage contact, this function makes it possible to reduce the maximum speed of fans and the number of compressors that can be activated. This operation is especially useful during the night phase, when the power required is very low, and the unit can operate at a reduced level, thus lowering the noise level during a sensitive time period.

Low noise execution

The units can be supplied in a low-noise version, with silencing housings and reduced speed BLDC fans. This configuration, together with the night-time attenuation function, significantly reduces the sound power level.

Primary heat pump management

In case of a decoupled circuit, it is possible, via remote sensor, to switch off the primary circuit's pumps, when permitted, due to low thermal load. In this manner a further reduction in pumping costs is achieved.

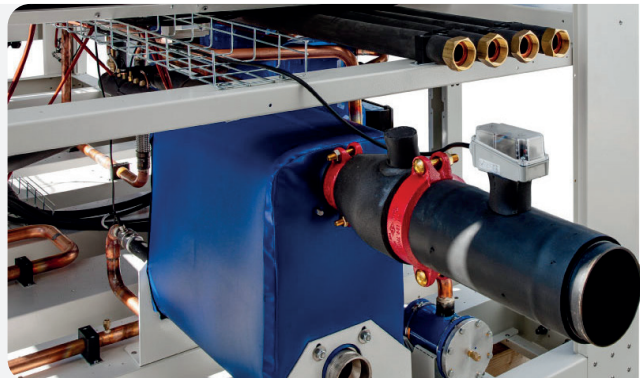

VLS Chillers and HP with Low GWP refrigerant

WATER CHILLERS RATED TECHNICAL DATA VLS C

| VLS C | | | 162 | 202 | 234 | 254 | 274 | 314 |
|--------------------------------------|--------|-----------------|-----------|-------|-------|-------|-------|-------|
| Power supply | | V-ph-Hz | 400-3N-50 | | | | | |
| Cooling capacity | (1)(E) | kW | 160 | 210 | 232 | 250 | 274 | 315 |
| Total power input | (1)(E) | kW | 58,3 | 67,3 | 73,9 | 85,0 | 102 | 116 |
| EER | (1)(E) | | 2,75 | 3,12 | 3,14 | 2,94 | 2,69 | 2,71 |
| SEER | (2)(E) | | 4,25 | 4,68 | 4,57 | 4,33 | 4,27 | 4,25 |
| Water flow | (1) | l/h | 27516 | 36134 | 39882 | 42982 | 47115 | 54152 |
| Water pressure drop | (1)(E) | kPa | 26 | 28 | 45 | 50 | 47 | 52 |
| Available pressure head - LP pumps | (1) | kPa | 118 | 150 | 120 | 107 | 99 | 83 |
| Available pressure head - HP pumps | (1) | kPa | 213 | 205 | 176 | 164 | 200 | 183 |
| Maximum current absorption | | A | 123 | 156 | 176 | 192 | 214 | 244 |
| Start up current | | A | 387 | 422 | 396 | 404 | 476 | 512 |
| Startup current with soft starter | | A | 301 | 335 | 331 | 339 | 393 | 425 |
| Compressors / circuits | | | 2/1 | 2/1 | 4/2 | 4/2 | 4/2 | 4/2 |
| Buffer tank volume | | dm ³ | 180 | 350 | 350 | 350 | 350 | 350 |
| Sound power level | (3)(E) | dB(A) | 89 | 91 | 89 | 90 | 91 | 91 |
| Sound power level, low-noise version | (3) | dB(A) | 85 | 85 | 84 | 84 | 84 | 85 |
| Sound power level quiet version | (3) | dB(A) | 83 | 83 | 82 | 82 | 82 | 83 |
| Weight without options | | kg | 1047 | 1744 | 1876 | 1783 | 1982 | 1994 |
| Maximum transport weight | | kg | 1188 | 1915 | 2048 | 1984 | 2125 | 2137 |

| VLS C | | | 344 | 374 | 414 | 456 | 546 | 576 |
|--------------------------------------|--------|-----------------|-----------|-------|-------|-------|-------|--------|
| Power supply | | V-ph-Hz | 400-3N-50 | | | | | |
| Cooling capacity | (1)(E) | kW | 344 | 370 | 420 | 475 | 545 | 590 |
| Total power input | (1)(E) | kW | 118 | 125 | 126 | 162 | 179 | 201 |
| EER | (1)(E) | | 2,92 | 2,96 | 3,33 | 2,93 | 3,04 | 2,94 |
| SEER | (2)(E) | | 4,43 | 4,33 | 4,78 | 4,61 | 4,64 | 4,62 |
| Water flow | (1) | l/h | 59124 | 63602 | 72187 | 81639 | 93660 | 101397 |
| Water pressure drop | (1)(E) | kPa | 36 | 39 | 30 | 35 | 41 | 46 |
| Available pressure head - LP pumps | (1) | kPa | 123 | 116 | 155 | 133 | 157 | 130 |
| Available pressure head - HP pumps | (1) | kPa | 228 | 222 | 213 | 190 | 199 | 173 |
| Maximum current absorption | | A | 263 | 278 | 312 | 362 | 415 | 460 |
| Start up current | | A | 537 | 550 | 585 | 624 | 642 | 734 |
| Startup current with soft starter | | A | 447 | 462 | 496 | 544 | 548 | 648 |
| Compressors / circuits | | | 4/2 | 4/2 | 4/2 | 6/2 | 6/2 | 6/2 |
| Buffer tank volume | | dm ³ | 550 | 550 | 700 | 700 | 850 | 850 |
| Sound power level | (3)(E) | dB(A) | 93 | 93 | 94 | 94 | 95 | 95 |
| Sound power level, low-noise version | (3) | dB(A) | 87 | 87 | 88 | 87 | 89 | 89 |
| Sound power level quiet version | (3) | dB(A) | 85 | 85 | 86 | 85 | 87 | 87 |
| Weight without options | | kg | 2557 | 2563 | 3233 | 3499 | 4090 | 4144 |
| Maximum transport weight | | kg | 2825 | 2832 | 3423 | 3689 | 4375 | 4429 |

(1) Outdoor air temperature 35°C, water temperature 12°C / 7°C (EN14511:2022)

(2) η efficiency values for heating and cooling are respectively calculated by the following formulas: $[\eta = SCOP / 2,5 - F(1) - F(2)]$ e $[\eta = SEER / 2,5 - F(1) - F(2)]$. For further information, please refer to the technical document "ErP 2009/125/EC DIRECTIVE" in the catalogue introducing pages, or to the EN14825:2022 regulation.

(3) Sound power level measured according to ISO 9614

(E) EUROVENT certified data

HEAT PUMPS RATED TECHNICAL DATA VLS H

| VLS H | | | 162 | 202 | 234 | 254 | 274 | 314 |
|--------------------------------------|--------|-----------------|-----------|-------|-------|-------|-------|-------|
| Power supply | | V-ph-Hz | 400-3N-50 | | | | | |
| Cooling capacity | (1)(E) | kW | 160 | 210 | 232 | 250 | 274 | 310 |
| Total power input | (1)(E) | kW | 58,5 | 67,7 | 73,9 | 85,0 | 102 | 116 |
| EER | (1)(E) | | 2,73 | 3,10 | 3,14 | 2,94 | 2,69 | 2,67 |
| SEER | (2)(E) | | 4,13 | 4,56 | 4,41 | 4,22 | 4,17 | 4,16 |
| Water flow | (1) | l/h | 27525 | 36122 | 39897 | 42992 | 47115 | 53291 |
| Water pressure drop | (1)(E) | kPa | 26 | 28 | 45 | 50 | 47 | 50 |
| Available pressure head - LP pumps | (1) | kPa | 117 | 151 | 121 | 108 | 99 | 82 |
| Available pressure head - HP pumps | (1) | kPa | 213 | 206 | 178 | 165 | 200 | 182 |
| Heating capacity | (3)(E) | kW | 167 | 224 | 256 | 264 | 290 | 330 |
| Total power input | (3)(E) | kW | 56,4 | 68,2 | 77,9 | 82,5 | 99,4 | 112 |
| COP | (3)(E) | | 2,96 | 3,28 | 3,29 | 3,20 | 2,92 | 2,95 |
| SCOP | (2)(E) | | 3,56 | 3,50 | 4,01 | 4,04 | 3,71 | 3,87 |
| Heating energy efficiency class | (4)(E) | | A+ | A+ | A++ | A++ | A+ | A++ |
| Water flow | (3) | l/h | 28975 | 38872 | 44430 | 45822 | 50334 | 57286 |
| Water pressure drop | (3)(E) | kPa | 29 | 32 | 55 | 56 | 53 | 57 |
| Available pressure head - LP pumps | (3) | kPa | 98 | 139 | 108 | 91 | 78 | 54 |
| Available pressure head - HP pumps | (3) | kPa | 193 | 194 | 164 | 148 | 178 | 153 |
| Maximum current absorption | | A | 123 | 156 | 176 | 192 | 214 | 244 |
| Start up current | | A | 387 | 422 | 396 | 404 | 476 | 512 |
| Startup current with soft starter | | A | 301 | 335 | 331 | 339 | 393 | 425 |
| Compressors / circuits | | | 2/1 | 2/1 | 4/2 | 4/2 | 4/2 | 4/2 |
| Buffer tank volume | | dm ³ | 180 | 350 | 350 | 350 | 350 | 350 |
| Sound power level | (5)(E) | dB(A) | 89 | 91 | 89 | 90 | 91 | 91 |
| Sound power level, low-noise version | (5) | dB(A) | 85 | 85 | 84 | 84 | 84 | 85 |
| Sound power level quiet version | (5) | dB(A) | 83 | 83 | 82 | 82 | 82 | 83 |
| Weight without options | | kg | 1155 | 2040 | 2172 | 1969 | 2174 | 2188 |
| Maximum transport weight | | kg | 1296 | 2241 | 2374 | 2149 | 2345 | 2360 |

(1) Outdoor air temperature 35°C, water temperature 12°C / 7°C (EN14511:2022)

(2) η efficiency values for heating and cooling are respectively calculated by the following formulas: [$\eta = SCOP / 2,5 - F(1) - F(2)$] e [$\eta = SEER / 2,5 - F(1) - F(2)$]. For further information, please refer to the technical document "ErP 2009/125/EC DIRECTIVE" in the catalogue introducing pages, or to the EN14825:2022 regulation.

(3) Outdoor air temperature dry bulb 7°C / wet bulb 6°C, water temperature 40°C / 45°C (EN14511:2022)

(4) Seasonal energy efficiency class for LOW TEMPERATURE room heating under AVERAGE climatic conditions [EUROPEAN REGULATION No 811/2013. The energy efficiency class of this product is included in the range A+++ → D]

(5) Sound power level measured according to ISO 9614

(E) EUROVENT certified data

VLS Chillers and HP with Low GWP refrigerant

HEAT PUMPS RATED TECHNICAL DATA VLS H

| VLS H | | | 344 | 374 | 414 | 456 | 546 | 576 |
|--------------------------------------|--------|-----------------|-----------|-------|-------|-------|-------|--------|
| Power supply | | V-ph-Hz | 400-3N-50 | | | | | |
| Cooling capacity | (1)(E) | kW | 343 | 366 | 418 | 472 | 543 | 585 |
| Total power input | (1)(E) | kW | 118 | 126 | 128 | 162 | 179 | 205 |
| EER | (1)(E) | | 2,91 | 2,90 | 3,26 | 2,91 | 3,03 | 2,85 |
| SEER | (2)(E) | | 4,35 | 4,23 | 4,69 | 4,60 | 4,61 | 4,60 |
| Water flow | (1) | l/h | 58960 | 62911 | 71831 | 81112 | 93327 | 100545 |
| Water pressure drop | (1)(E) | kPa | 36 | 38 | 30 | 35 | 41 | 45 |
| Available pressure head - LP pumps | (1) | kPa | 124 | 117 | 157 | 134 | 159 | 132 |
| Available pressure head - HP pumps | (1) | kPa | 229 | 223 | 214 | 191 | 201 | 175 |
| Heating capacity | (3)(E) | kW | 370 | 391 | 443 | 505 | 572 | 627 |
| Total power input | (3)(E) | kW | 115 | 125 | 129 | 164 | 178 | 196 |
| COP | (3)(E) | | 3,21 | 3,13 | 3,42 | 3,08 | 3,21 | 3,20 |
| SCOP | (2)(E) | | 3,68 | 3,72 | 3,65 | 3,42 | 3,65 | 3,80 |
| Heating energy efficiency class | (4)(E) | | A+ | | | | | |
| Water flow | (3) | l/h | 64235 | 67894 | 76926 | 87689 | 99325 | 108888 |
| Water pressure drop | (3)(E) | kPa | 42 | 44 | 34 | 40 | 46 | 52 |
| Available pressure head - LP pumps | (3) | kPa | 109 | 102 | 143 | 113 | 130 | 95 |
| Available pressure head - HP pumps | (3) | kPa | 214 | 207 | 200 | 168 | 172 | 138 |
| Maximum current absorption | | A | 263 | 278 | 312 | 362 | 415 | 460 |
| Start up current | | A | 537 | 550 | 585 | 624 | 642 | 734 |
| Startup current with soft starter | | A | 447 | 462 | 496 | 544 | 548 | 648 |
| Compressors / circuits | | | 4/2 | 4/2 | 4/2 | 6/2 | 6/2 | 6/2 |
| Buffer tank volume | | dm ³ | 550 | 550 | 700 | 700 | 850 | 850 |
| Sound power level | (5)(E) | dB(A) | 93 | 93 | 94 | 94 | 95 | 95 |
| Sound power level, low-noise version | (5) | dB(A) | 87 | 87 | 88 | 87 | 89 | 89 |
| Sound power level quiet version | (5) | dB(A) | 85 | 85 | 86 | 85 | 87 | 87 |
| Weight without options | | kg | 2869 | 2876 | 3623 | 3889 | 4641 | 4697 |
| Maximum transport weight | | kg | 2909 | 2930 | 3813 | 4079 | 4926 | 4982 |

(1) Outdoor air temperature 35°C, water temperature 12°C / 7°C (EN14511:2022)

(2) η efficiency values for heating and cooling are respectively calculated by the following formulas: $[\eta = SCOP / 2,5 - F(1) - F(2)]$ e $[\eta = SEER / 2,5 - F(1) - F(2)]$. For further information, please refer to the technical document "ErP 2009/125/EC DIRECTIVE" in the catalogue introducing pages, or to the EN14825:2022 regulation.

(3) Outdoor air temperature dry bulb 7°C / wet bulb 6°C, water temperature 40°C / 45°C (EN14511:2022)

(4) Seasonal energy efficiency class for LOW TEMPERATURE room heating under AVERAGE climatic conditions [EUROPEAN REGULATION No 811/2013. The energy efficiency class of this product is included in the range A+++ → D]

(5) Sound power level measured according to ISO 9614

(E) EUROVENT certified data

DIMENSIONAL DRAWINGS

VLS 162 C

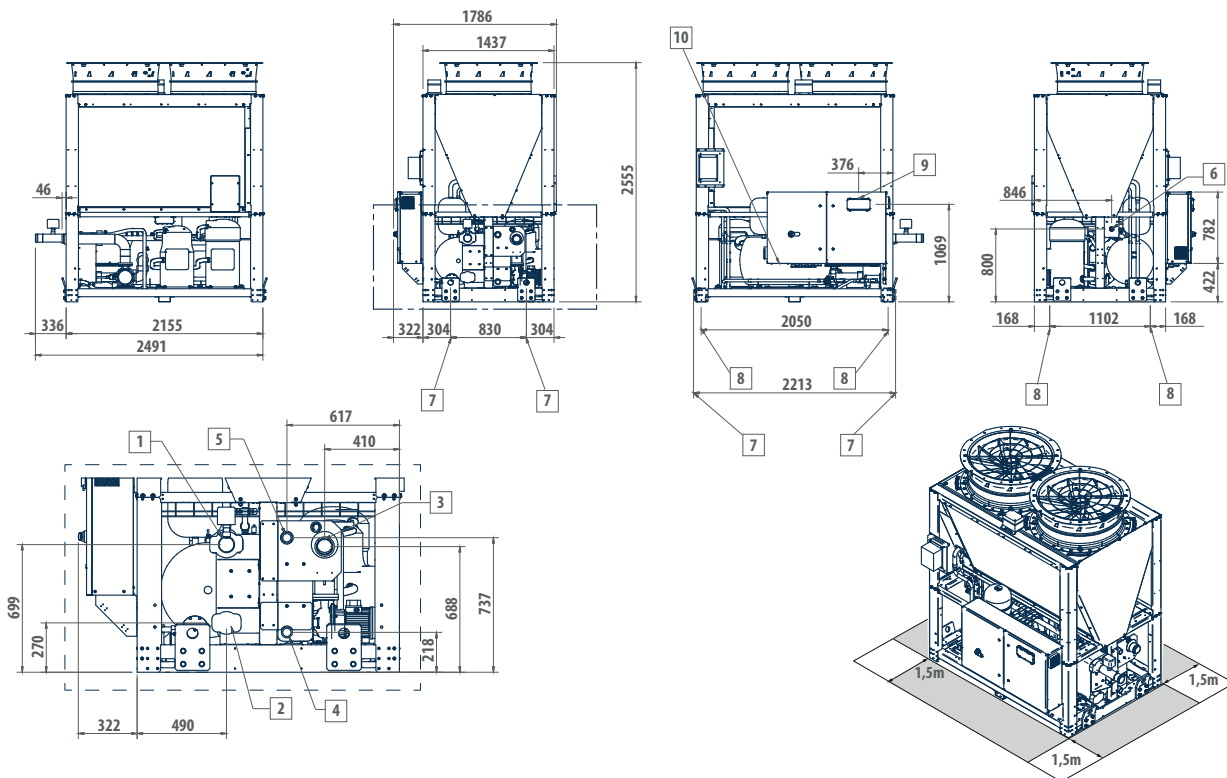

LEGEND

| | |
|----|--|
| 1 | Water inlet Victaulic 3" |
| 2 | Water outlet, evaporator only Victaulic 3" |
| 3 | Water outlet pump and/or tank Victaulic 3" |
| 4 | Heat exchanger inlet 2" M |
| 5 | Heat exchanger outlet 2" M |
| 6 | Outlet safety valve 1" M |
| 7 | Lifting points |
| 8 | Vibration dumpers |
| 9 | User interface |
| 10 | Power supply input |

VLS Chillers and HP with Low GWP refrigerant

DIMENSIONAL DRAWINGS

VLS 162 H

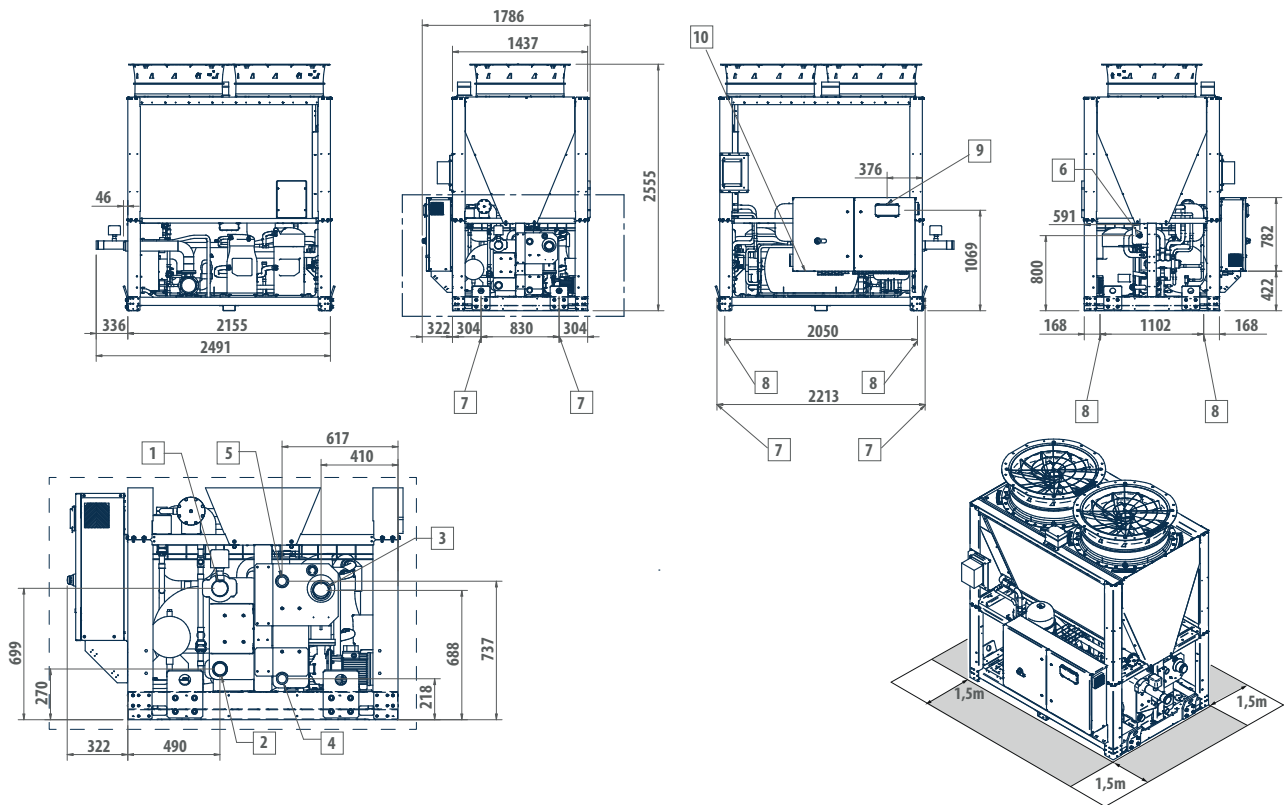

LEGEND

| | |
|----|--|
| 1 | Water inlet Victaulic 3" |
| 2 | Water outlet, evaporator only Victaulic 3" |
| 3 | Water outlet pump and/or tank Victaulic 3" |
| 4 | Heat exchanger inlet 2" M |
| 5 | Heat exchanger outlet 2" M |
| 6 | Outlet safety valve 1" M |
| 7 | Lifting points |
| 8 | Vibration dumpers |
| 9 | User interface |
| 10 | Power supply input |

DIMENSIONAL DRAWINGS

VLS C 202 mono circuit

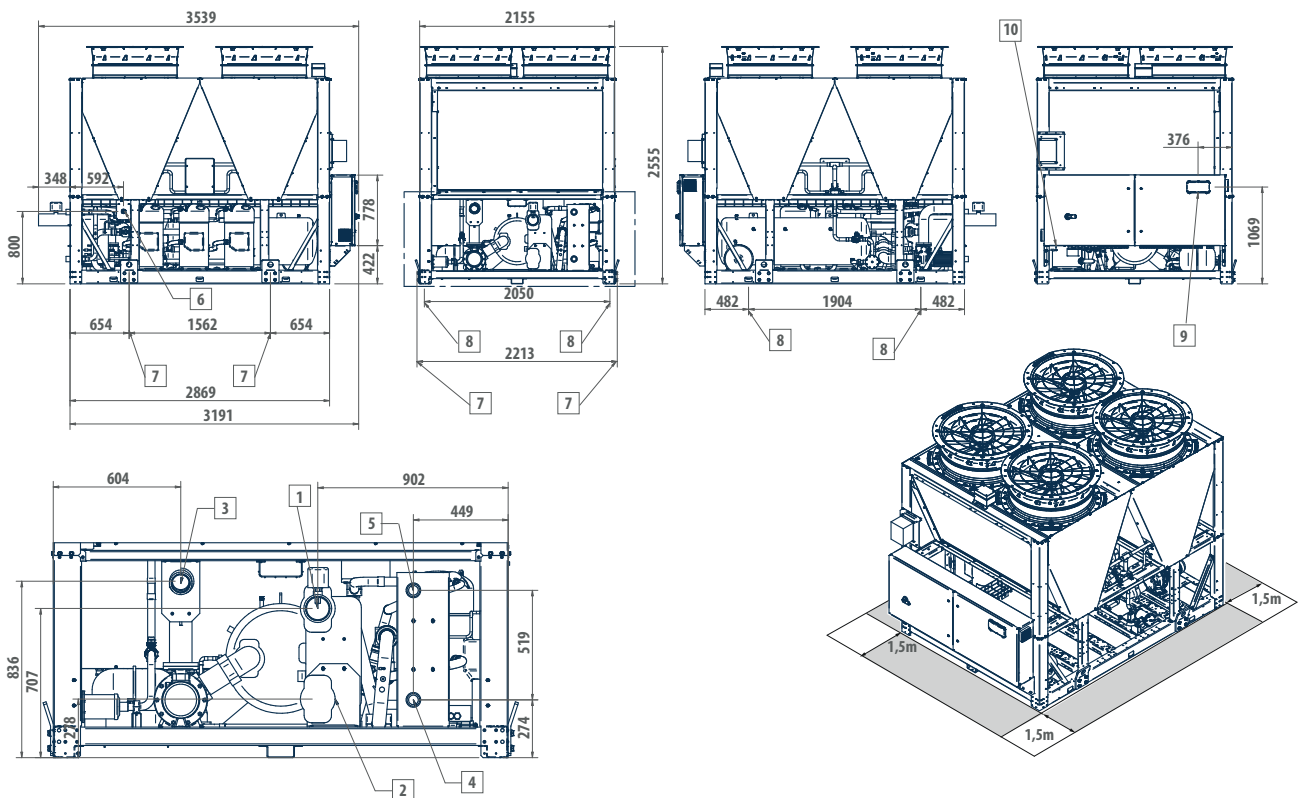

LEGEND

| | |
|----|--|
| 1 | Water inlet Victaulic 4" |
| 2 | Water outlet, evaporator only Victaulic 4" |
| 3 | Water outlet pump and/or tank Victaulic 4" |
| 4 | Heat exchanger inlet 2" M |
| 5 | Heat exchanger outlet 2" M |
| 6 | Outlet safety valve 1" M |
| 7 | Lifting points |
| 8 | Vibration dumpers |
| 9 | User interface |
| 10 | Power supply input |

VLS Chillers and HP with Low GWP refrigerant

DIMENSIONAL DRAWINGS

VLS H 202 mono circuit

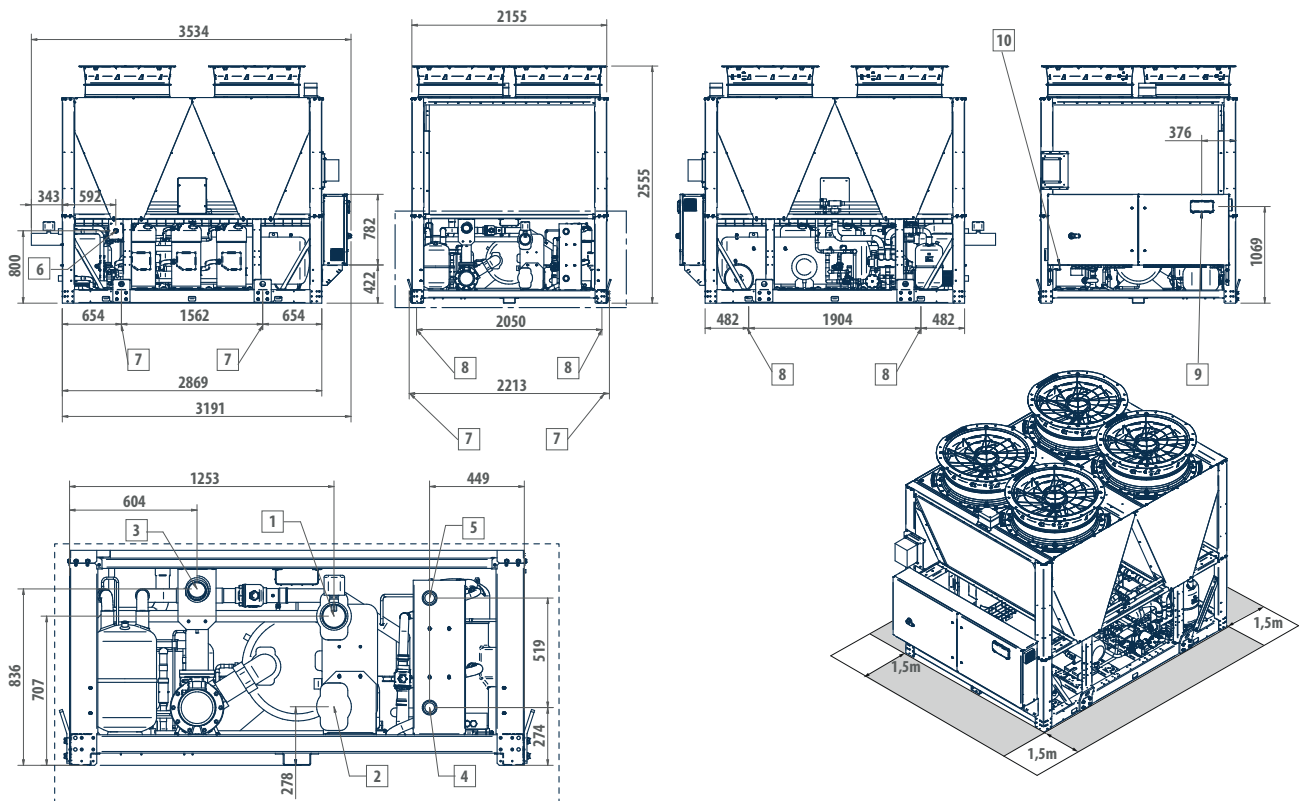

LEGEND

| | |
|----|--|
| 1 | Water inlet Victaulic 4" |
| 2 | Water outlet, evaporator only Victaulic 4" |
| 3 | Water outlet pump and/or tank Victaulic 4" |
| 4 | Heat exchanger inlet 2" M |
| 5 | Heat exchanger outlet 2" M |
| 6 | Outlet safety valve 1" M |
| 7 | Lifting points |
| 8 | Vibration dumpers |
| 9 | User interface |
| 10 | Power supply input |

DIMENSIONAL DRAWINGS

VLS C 234; 254 - 314 double circuit

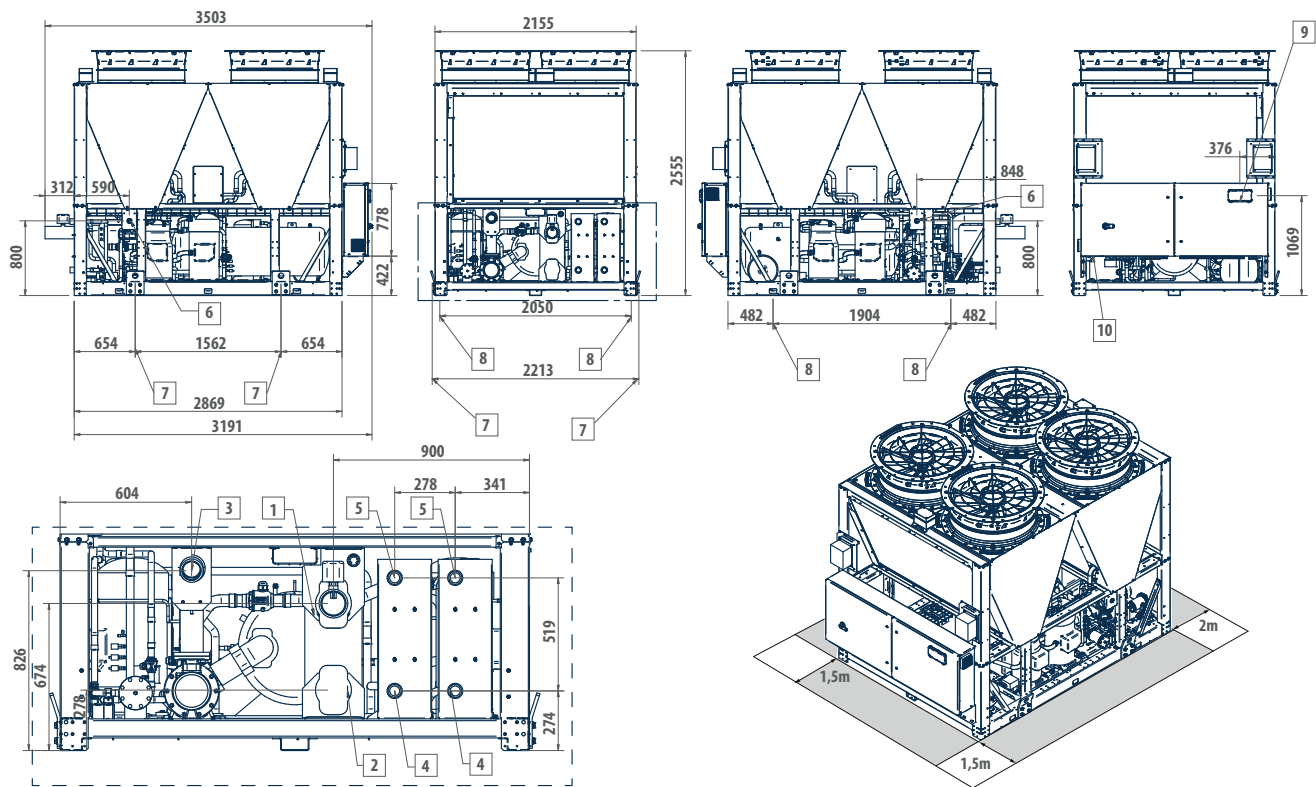

LEGEND

| | |
|----|--|
| 1 | Water inlet Victaulic 4" |
| 2 | Water outlet, evaporator only Victaulic 4" |
| 3 | Water outlet pump and/or tank Victaulic 4" |
| 4 | Heat exchanger inlet 2" M |
| 5 | Heat exchanger outlet 2" M |
| 6 | Outlet safety valve 1" M |
| 7 | Lifting points |
| 8 | Vibration dumpers |
| 9 | User interface |
| 10 | Power supply input |

VLS Chillers and HP with Low GWP refrigerant

DIMENSIONAL DRAWINGS

VLS H 234; 254 - 314 double circuit

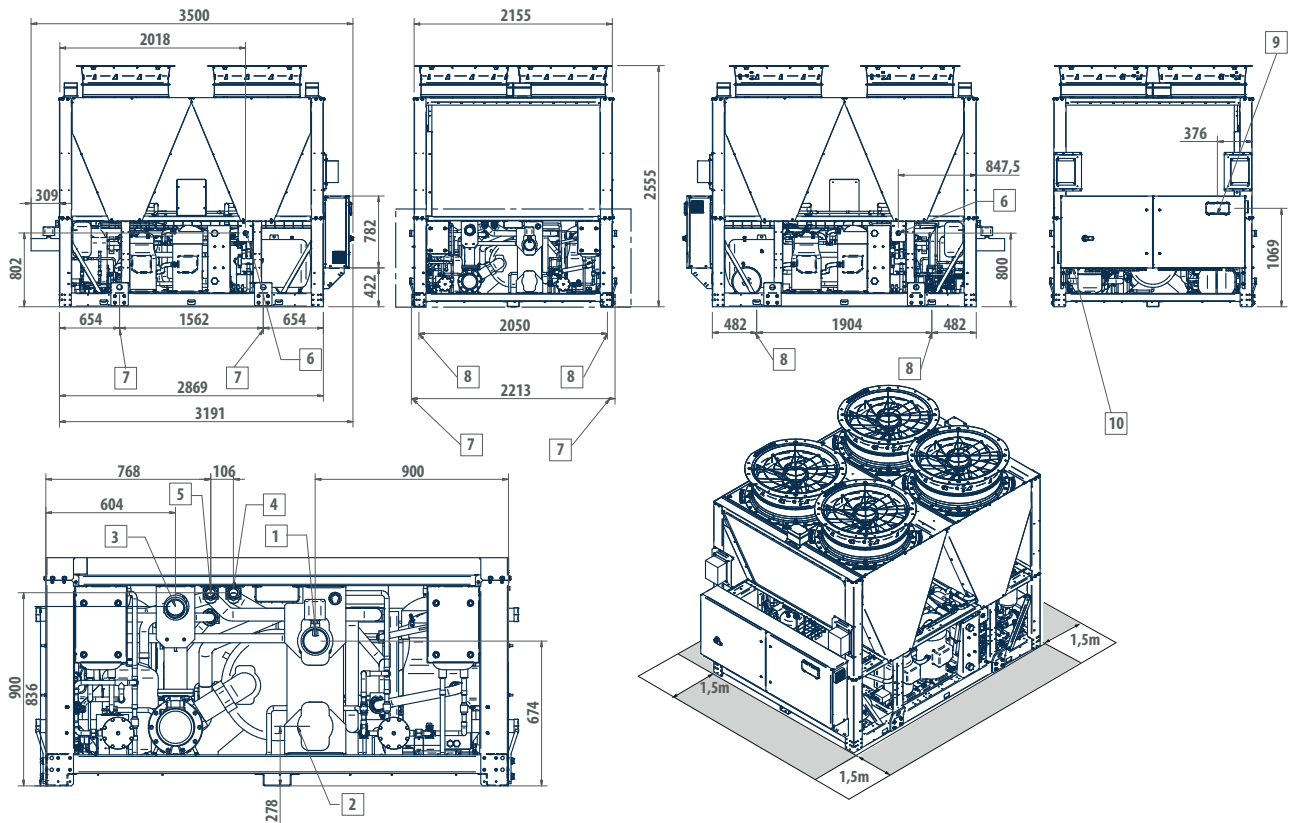

LEGEND

| | |
|----|--|
| 1 | Water inlet Victaulic 4" |
| 2 | Water outlet, evaporator only Victaulic 4" |
| 3 | Water outlet pump and/or tank Victaulic 4" |
| 4 | Heat exchanger inlet 2" M |
| 5 | Heat exchanger outlet 2" M |
| 6 | Outlet safety valve 1" M |
| 7 | Lifting points |
| 8 | Vibration dumpers |
| 9 | User interface |
| 10 | Power supply input |

DIMENSIONAL DRAWINGS

VLS C 344 - 374

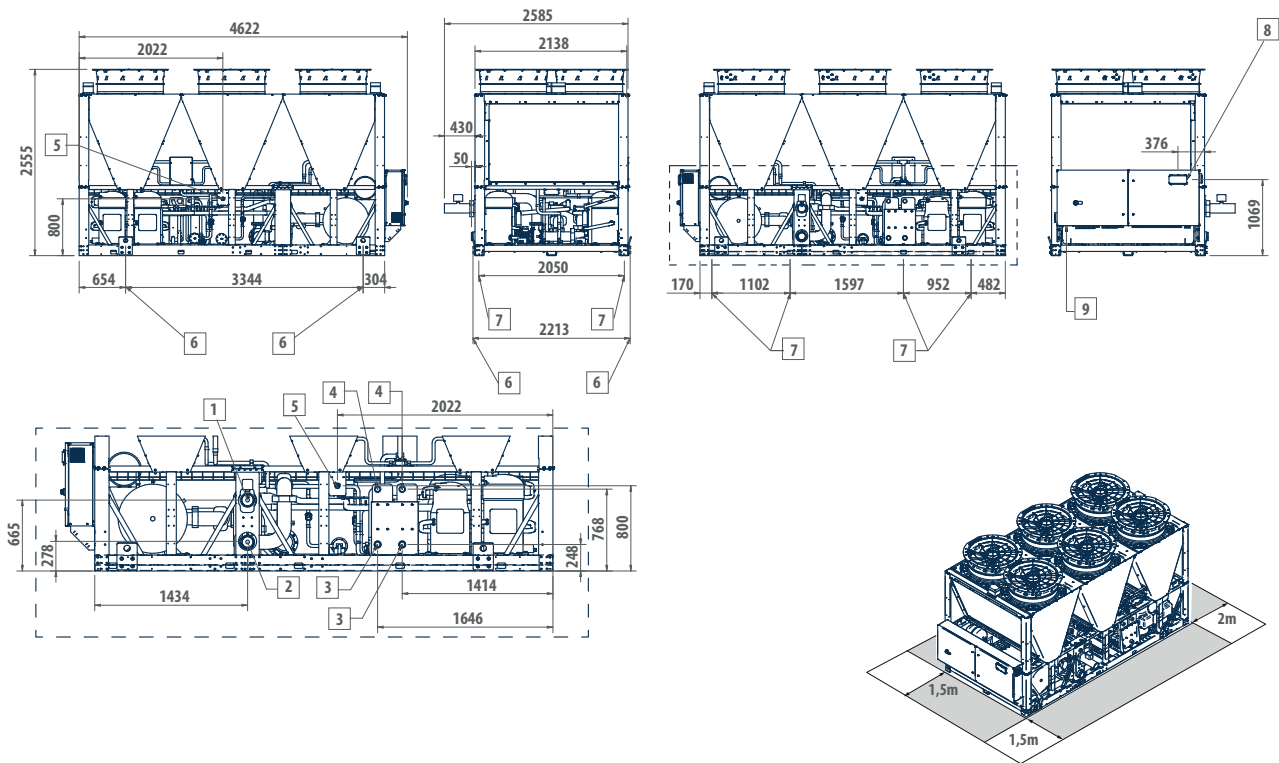

LEGEND

| | |
|---|----------------------------|
| 1 | Water inlet Victaulic 4" |
| 2 | Water outlet Victaulic 4" |
| 3 | Heat exchanger inlet 2" M |
| 4 | Heat exchanger outlet 2" M |
| 5 | Outlet safety valve 1" M |
| 6 | Lifting points |
| 7 | Vibration dumpers |
| 8 | User interface |
| 9 | Power supply input |

VLS Chillers and HP with Low GWP refrigerant

DIMENSIONAL DRAWINGS

VLS H 344 - 374

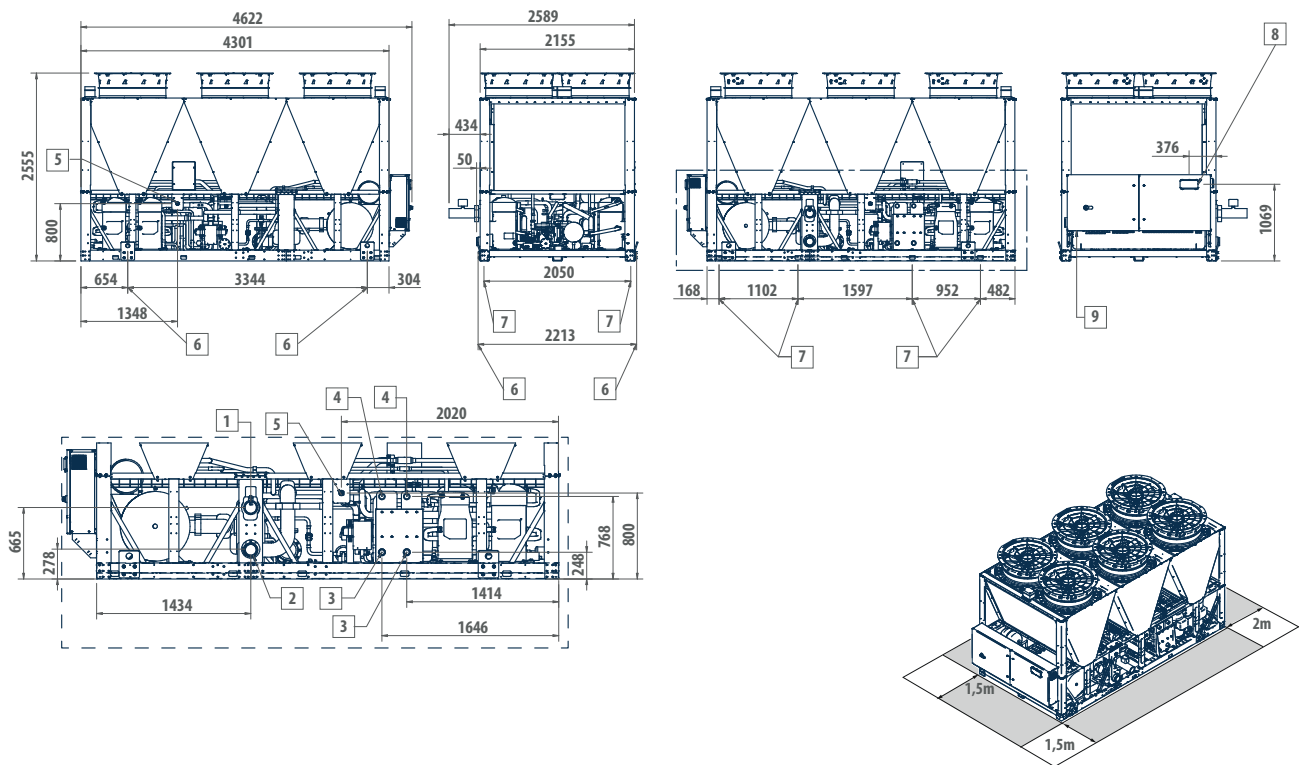

LEGEND

| | |
|---|----------------------------|
| 1 | Water inlet Victaulic 4" |
| 2 | Water outlet Victaulic 4" |
| 3 | Heat exchanger inlet 2" M |
| 4 | Heat exchanger outlet 2" M |
| 5 | Outlet safety valve 1" M |
| 6 | Lifting points |
| 7 | Vibration dumpers |
| 8 | User interface |
| 9 | Power supply input |

DIMENSIONAL DRAWINGS

VLS C 414 - 456

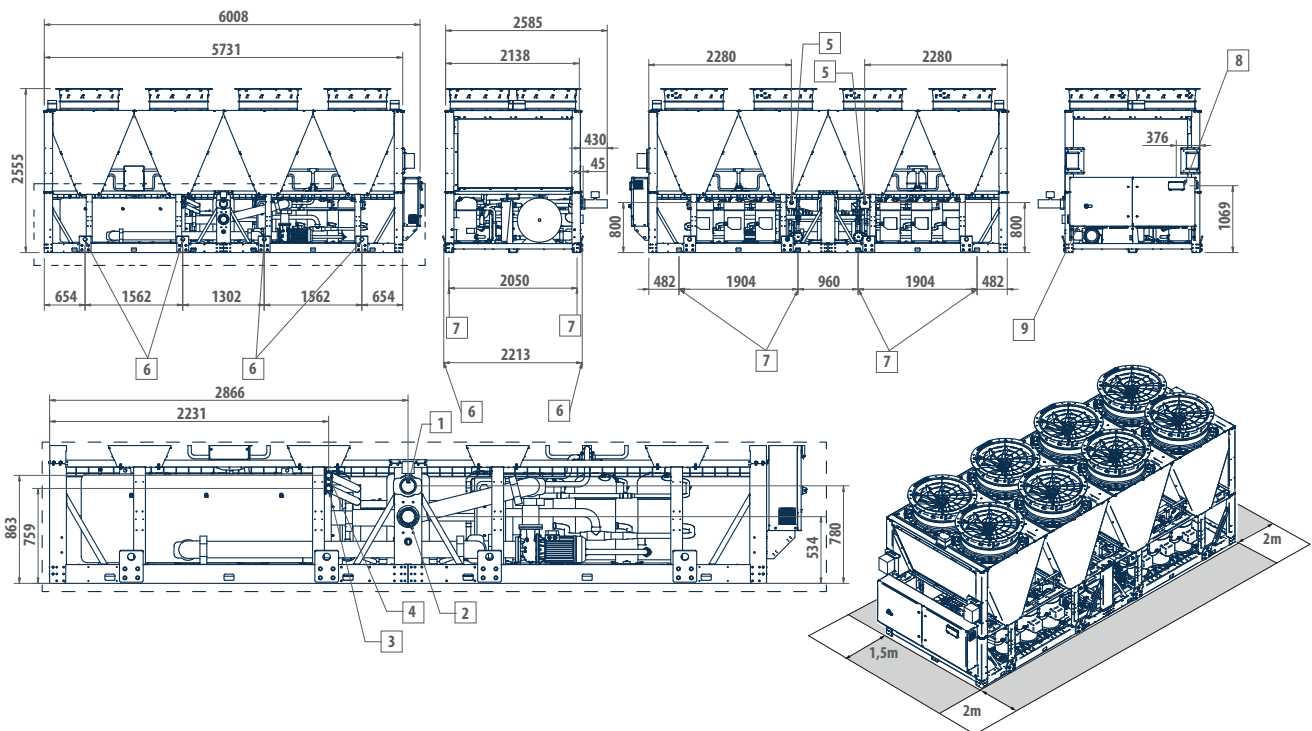

LEGEND

| | |
|---|----------------------------|
| 1 | Water inlet Victaulic 4" |
| 2 | Water outlet Victaulic 4" |
| 3 | Heat exchanger inlet 2" M |
| 4 | Heat exchanger outlet 2" M |
| 5 | Outlet safety valve 1" M |
| 6 | Lifting points |
| 7 | Vibration dumpers |
| 8 | User interface |
| 9 | Power supply input |

VLS Chillers and HP with Low GWP refrigerant

DIMENSIONAL DRAWINGS

VLS H 414 - 456

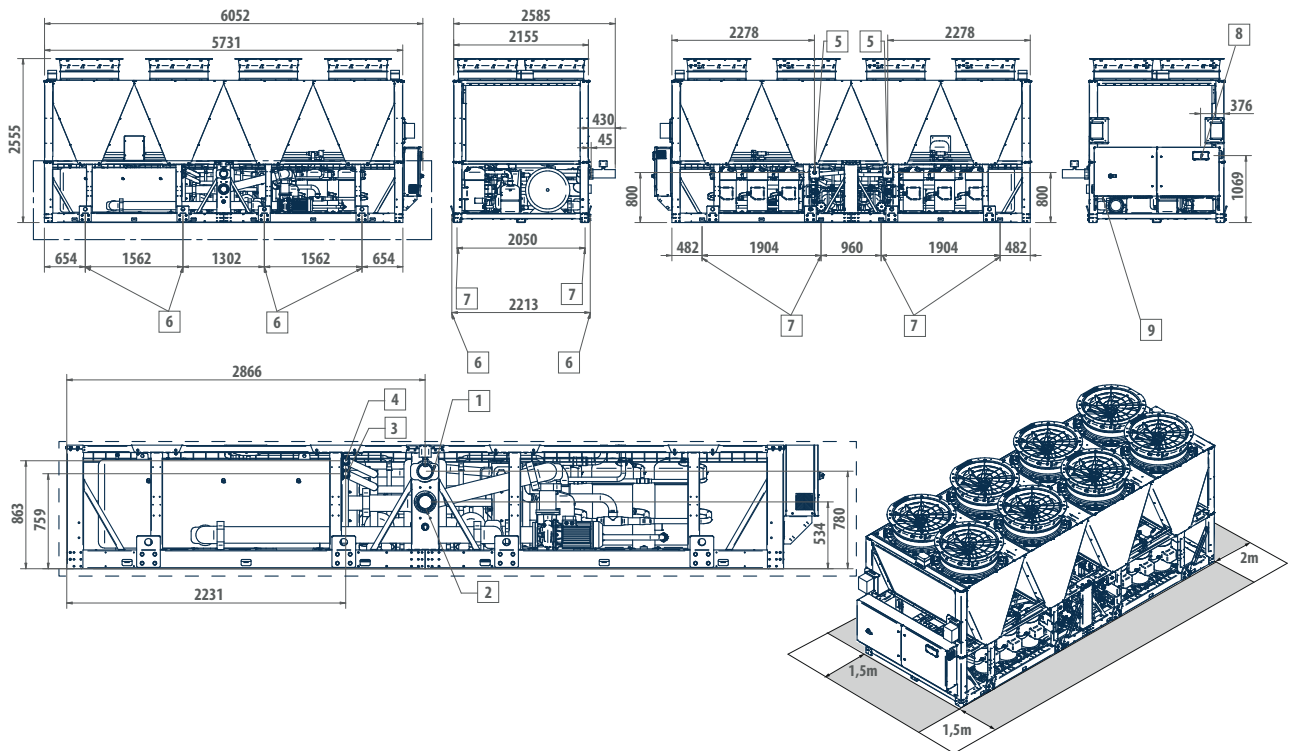

LEGEND

| | |
|---|----------------------------|
| 1 | Water inlet Victaulic 4" |
| 2 | Water outlet Victaulic 4" |
| 3 | Heat exchanger inlet 2" M |
| 4 | Heat exchanger outlet 2" M |
| 5 | Outlet safety valve 1" M |
| 6 | Lifting points |
| 7 | Vibration dumpers |
| 8 | User interface |
| 9 | Power supply input |

DIMENSIONAL DRAWINGS

VLS C 546 - 576

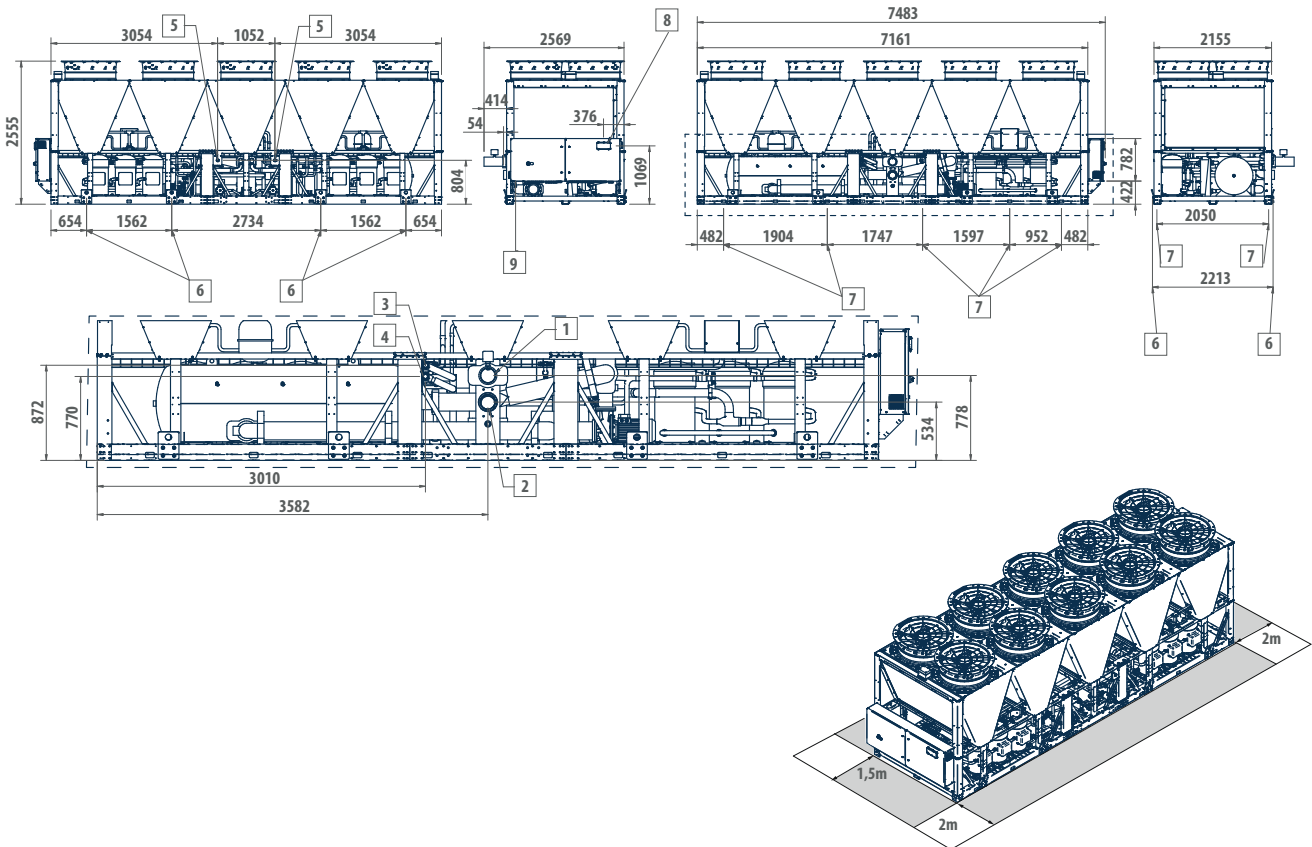

LEGEND

| | |
|---|----------------------------|
| 1 | Water inlet Victaulic 5" |
| 2 | Water outlet Victaulic 5" |
| 3 | Heat exchanger inlet 2" M |
| 4 | Heat exchanger outlet 2" M |
| 5 | Outlet safety valve 1" M |
| 6 | Lifting points |
| 7 | Vibration dumpers |
| 8 | User interface |
| 9 | Power supply input |

VLS Chillers and HP with Low GWP refrigerant

DIMENSIONAL DRAWINGS

VLS H 546 - 576

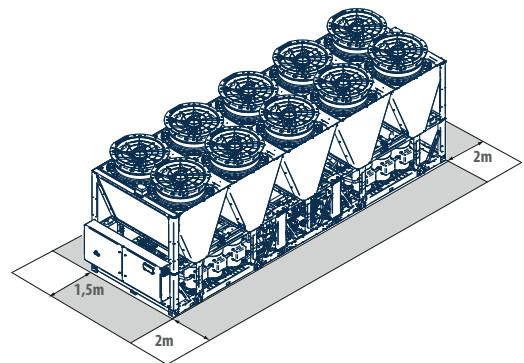
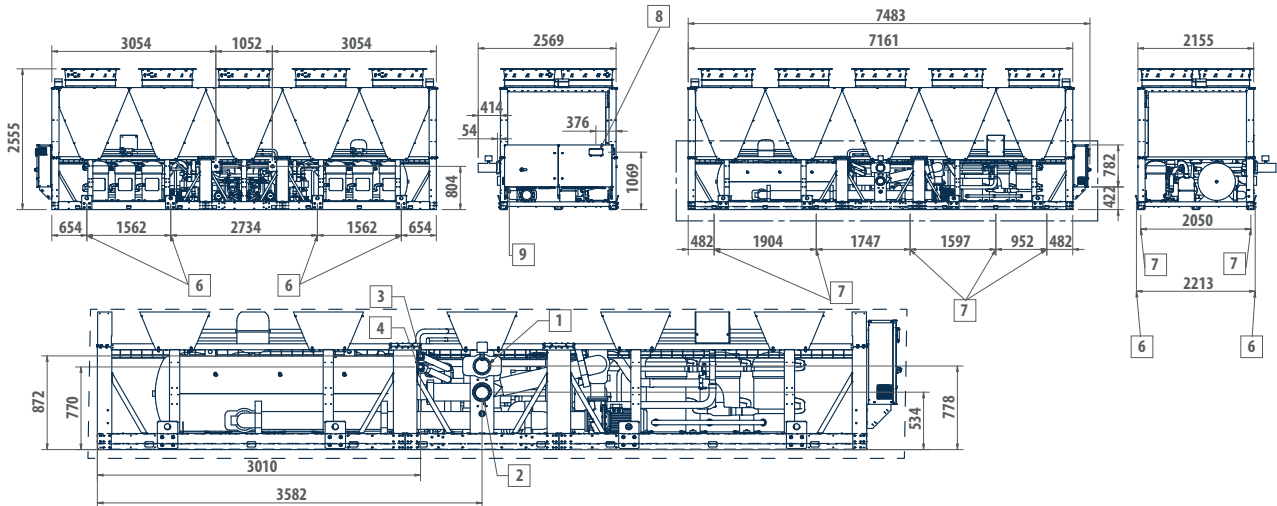

LEGEND

| | |
|---|----------------------------|
| 1 | Water inlet Victaulic 5" |
| 2 | Water outlet Victaulic 5" |
| 3 | Heat exchanger inlet 2" M |
| 4 | Heat exchanger outlet 2" M |
| 5 | Outlet safety valve 1" M |
| 6 | Lifting points |
| 7 | Vibration dumpers |
| 8 | User interface |
| 9 | Power supply input |