

Indoor or outdoor packaged unit

WBZ 45 - 220 kW



R-1234ze Refrigerant



Scroll compressor



Heating only

PLUS

- » R1234ze refrigerant (GWP=1,37)
- » Up to 4 compressors
- » Remote connectivity with the most common protocols
- » Compact dimensions
- » Three different acoustic configurations
- » High seasonal efficiency values
- » Production of water up to 90°C
- » Minimum source-side water temperature of 5°C

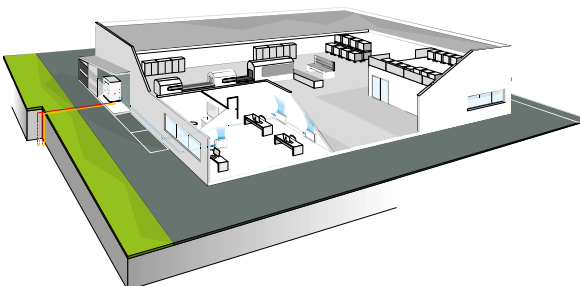

Booster unit for high-temperature water production. Indoor or outdoor installation, featuring high seasonal efficiency with very low GWP refrigerant.

WBZ is the new Galletti series of non-reversible water-cooled heat pumps for high-temperature water production. The new Galletti booster is capable of working with low or medium-temperature sources.

WBZ can be installed both outdoors and indoors.

The use of the refrigerant R1234ze enables full compliance with the limits set by the new F-GAS Regulation on the use of fluorinated gases. Indeed, this fluid has one of the lowest GWP values currently available on the market, namely 1.37, which is well below the limit of 150 set by current legislation.

R1234ze is a refrigerant classified as slightly flammable (class A2L); for this reason, a leak detection sensor is installed on board and a dedicated safety procedure has been implemented.

The range covers a power range starting from 45 kW up to a maximum of 220 kW, and is characterized by high levels of seasonal efficiency and reduced footprints to facilitate access to technical rooms.

The use of top-quality, state-of-the-art components in the cooling, hydraulic, and electrical sections makes WBZ booster units state-of-the-art in terms of efficiency, reliability, and operating limits.

The WBZ range is designed to produce high-temperature water, up to 90 °C, evaporating on a medium-temperature thermal source (typically at 45 °C), making it ideal for cascade use with air-cooled heat pumps. Furthermore, thanks to the wide operating range on the source side, it can operate even with very low temperatures, down to 5 °C, independently guaranteeing the entire thermal lift required by the system.

The high configurability of the series, inherent to Galletti's DNA, is guaranteed by 2 different construction versions, with and without closing panels, and 3 different acoustic setups: standard, low-noise, and super low-noise, capable of ensuring a reduction in sound power level of up to 6 dB(A).

The advanced microprocessor that regulates the unit's operation finally allows for the control of a maximum of 2 user-side pumps and 2 source-side pumps, either on/off or modulating.

EXTENDED OPERATING RANGE FOR EACH APPLICATION

With Galletti WBZ allows for the selection of a 'low source-side temperature' option, extending the operating envelope for applications with lower source temperatures.

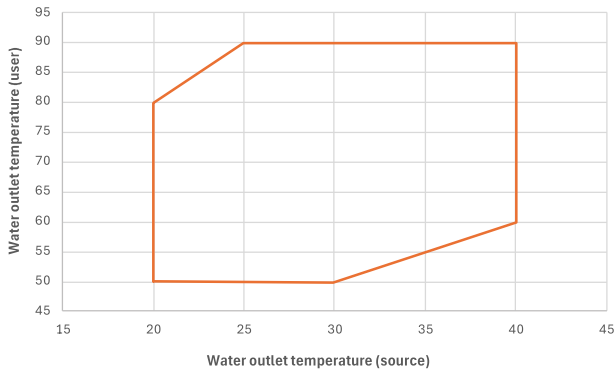
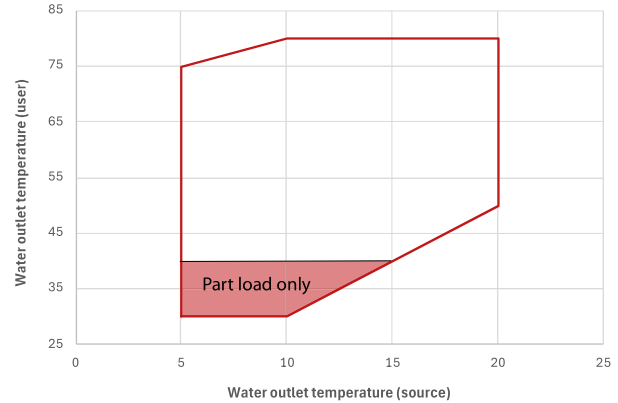
High source T operating range

Low source T operating range

CONFIGURATOR

The models are completely configurable by selecting the version and the options. To the right is shown an example of configuration.

Version	Field	1	2	3	4	5	6	7	8	9	10
WBE		2	B	0	1	1	0	0	0	0	0

To verify the compatibility of the options, use the selection software or the price list.

AVAILABLE VERSIONS

WBZ...VVS
WBZ...VVL
WBZ...VVQ

Heating only, standard execution
Heating only, low noise execution
Heating only, super low noise execution

CONFIGURATION OPTIONS

- 1 Power supply**
 - 2 400 - 3 - 50 + N + circuit breakers
 - 5 400 - 3 - 50 + circuit breakers
- 2 Control microprocessor and lamination device**
 - B Advanced + electronic expansion valve
 - X Advanced + electronic expansion valve for source side low T
- 3 Partial heat recovery**
 - 0 Absent
- 4 Source water flow modulation**
 - 1 Single pump
 - 2 Dual pump
 - 3 Single pump + condensation control with 0-10V modulated output signal
 - 4 Dual pump + condensation control with 0-10V modulated output signal
- 5 User water flow modulation**
 - 1 Single pump
 - 2 Dual pump
 - 3 Single pump + output signal with water flow modulation in ΔT logic = cost
 - 4 Dual pump + output signal with water flow modulation in ΔT logic = cost
 - 5 Single pump + output signal with water flow modulation in T logic = cost
 - 6 Dual pump + output signal with water flow modulation in T logic = cost

- 6 Remote communication**
 - 0 Absent
 - 1 RS485 serial card (Modbus or Carel protocol)
 - 4 Ethernet card (SNMP or BACNET protocol)
 - 5 Ethernetkaart + supervisiessoftware
- 7 Anti vibration shock mounts**
 - 0 Absent
 - G Rubber vibration dampers at the base of the unit
 - M Spring vibration dampers at the base of the unit
- 8 Packing**
 - 0 Standard
 - 1 Wooden cage
 - 2 Wooden crate
- 9 Remote control**
 - 0 Absent
 - 1 Simplified remote control panel
 - 3 Remote display for programmable microprocessor
- 10 Anti-intrusion panelling**
 - 0 Absent
 - P Present (standard for Q version)

ACCESSORIES

A	Power factor capacitors	L	Filter regulating kit (supplied)
B	Soft starter	M	Set point compensation outdoor temperature probe (supplied)
C	Smart Grid Certification	N	Compressor tandem/trio isolation valves
E	ON/OFF status of the compressors	P	Unit lifting pipes
F	Remote free contact for capacity limitation	Q	Temperature probe for pump shutdown on the primary circuit
G	Configurable digital alarm card	T	Mains power analyzer for monitoring and reducing power consumption
H	Refrigerant pressure gauges	V	Set-point modification with 4-20mA signal
I	Two pairs of Victaulic joints	4	2 Dirt separators (supplied as an accessory)

High-temperature non-reversible heat pump with Low GWP Refrigerant WBZ

WBZ HEAT PUMP RATED TECHNICAL DATA

WBZ			051	061	082	092	122
Power supply		V-ph-Hz	400/3N/50				
Heating capacity	(1)(E)	kW	47,4	56,9	80,0	94,4	115
Total power input	(1)(E)	kW	10,3	12,7	17,8	20,3	25,3
COP	(1)(E)		4,62	4,49	4,49	4,64	4,55
SCOP	(2)		4,21	3,88	4,40	4,46	4,16
Heating energy efficiency class	(3)		A+++				
Water flow user side	(1)(E)	l/h	5220	6259	8803	10385	12685
Water pressure drop user side	(1)	kPa	20	36	25	25	25
Water flow source side	(1)(E)	l/h	6549	7792	10957	13043	15849
Water pressure drop source side	(1)	kPa	32	58	32	42	51
Maximum current absorption		A	29,0	35,0	49,0	59,0	69,0
Start up current		A	156	174	135	185	209
Startup current with soft starter		A	94	104	91	123	139
no. of compressors / circuits			1/1	1/1	2/1	2/1	2/1
Sound power level	(4)(E)	dB(A)	79	80	81	81	82
Height		mm	1034	1034	1034	1034	1957
Length		mm	1817	1817	1817	1817	1813
Depth		mm	799	799	799	799	799
Maximum transport weight		kg	308	313	393	400	620

(1) Water temperature - user side 70/78 °C, water temperature - source side 40 °C / 45 °C (EN14511:2022)

(2) η efficiency values for heating and cooling are respectively calculated by the following formulas: $[\eta = SCOP / 2,5 - F(1) - F(2)]$ e $[\eta = SEER / 2,5 - F(1) - F(2)]$. For further information, please refer to the technical document "ErP 2009/125/EC DIRECTIVE" in the catalogue introducing pages, or to the EN14825:2022 regulation. Medium temperature conditions.

(3) Seasonal energy efficiency class for MEDIUM TEMPERATURE room heating under AVERAGE climatic conditions [EUROPEAN REGULATION No 811/2013]

(4) If the two cooling circuits are unbalanced, it is the smaller circuit. Kg gas value is estimated. For the exact value refer to the plate data on the unit.

(E) EUROVENT certified data

WBZ			164	184	194	224
Power supply		V-ph-Hz	400/3N/50			
Heating capacity	(1)(E)	kW	156	177	189	220
Total power input	(1)(E)	kW	35,4	38,7	40,8	51,3
COP	(1)(E)		4,42	4,56	4,63	4,29
SCOP	(2)		4,47	4,42	4,71	4,09
Heating energy efficiency class	(3)		A+++			
Water flow user side	(1)(E)	l/h	17212	19425	20807	24221
Water pressure drop user side	(1)	kPa	15	18	20	20
Water flow source side	(1)(E)	l/h	21343	24283	261220	29778
Water pressure drop source side	(1)	kPa	27	35	39	38
Maximum current absorption		A	99,0	109	117	139
Start up current		A	184	206	244	278
Startup current with soft starter		A	140	156	182	209
no. of compressors / circuits			4/2			
Sound power level	(4)(E)	dB(A)	84	84	84	85
Height		mm	1957	1957	1957	1957
Length		mm	2265	2265	2265	2265
Depth		mm	799	799	799	799
Maximum transport weight		kg	905	929	938	1010

(1) Water temperature - user side 70/78 °C, water temperature - source side 40 °C / 45 °C (EN14511:2022)

(2) η efficiency values for heating and cooling are respectively calculated by the following formulas: $[\eta = SCOP / 2,5 - F(1) - F(2)]$ e $[\eta = SEER / 2,5 - F(1) - F(2)]$. For further information, please refer to the technical document "ErP 2009/125/EC DIRECTIVE" in the catalogue introducing pages, or to the EN14825:2022 regulation. Medium temperature conditions.

(3) Seasonal energy efficiency class for MEDIUM TEMPERATURE room heating under AVERAGE climatic conditions [EUROPEAN REGULATION No 811/2013]

(4) If the two cooling circuits are unbalanced, it is the smaller circuit. Kg gas value is estimated. For the exact value refer to the plate data on the unit.

(E) EUROVENT certified data

DIMENSIONAL DRAWINGS

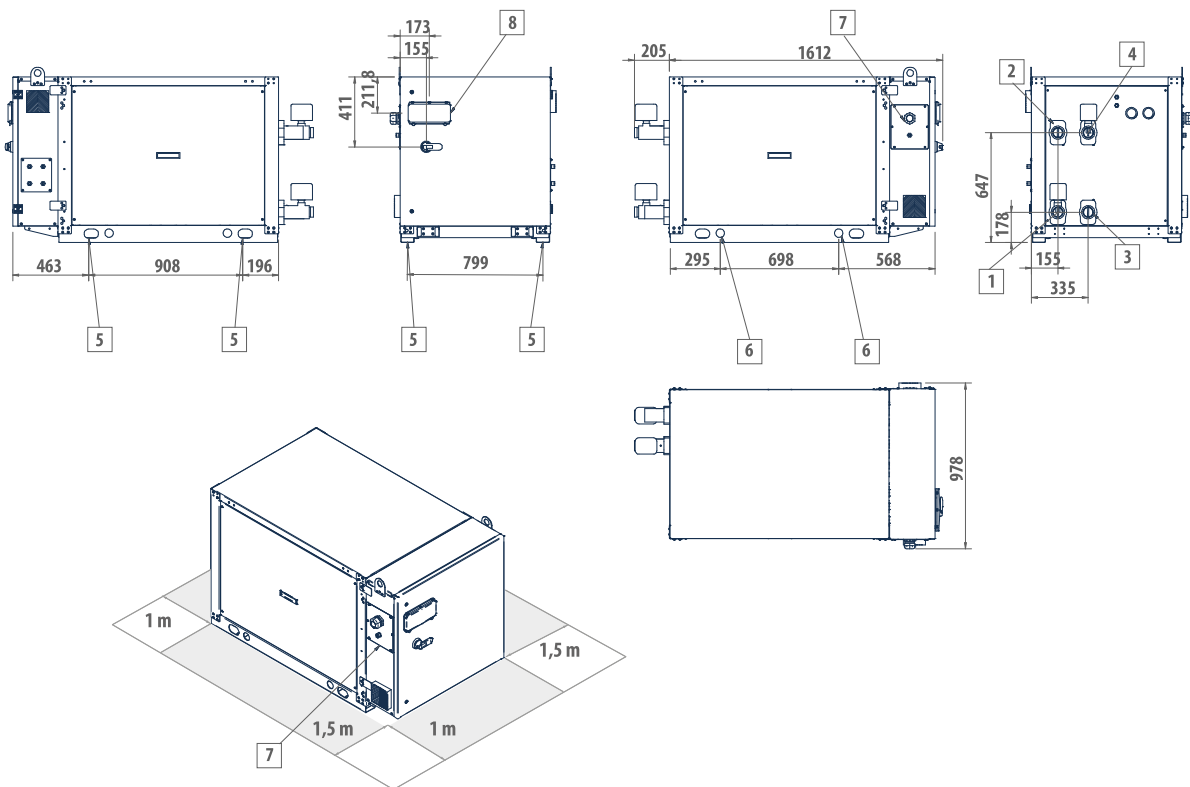
WBZ 051-061-082-092

LEGEND

- | | |
|---|---------------------------------------|
| 1 | User side water inlet 2" Victaulic |
| 2 | User side water outlet 2" Victaulic |
| 3 | Source side water outlet 2" Victaulic |
| 4 | Source side water inlet 2" Victaulic |
| 5 | Vibration dampers |
| 6 | Lifting points |
| 7 | Power supply input |
| 8 | User interface |

Closing panelling available on request
For maintenance requirements, keep at least 0.5 m of clearance from the ceiling.

DIMENSIONAL DRAWINGS

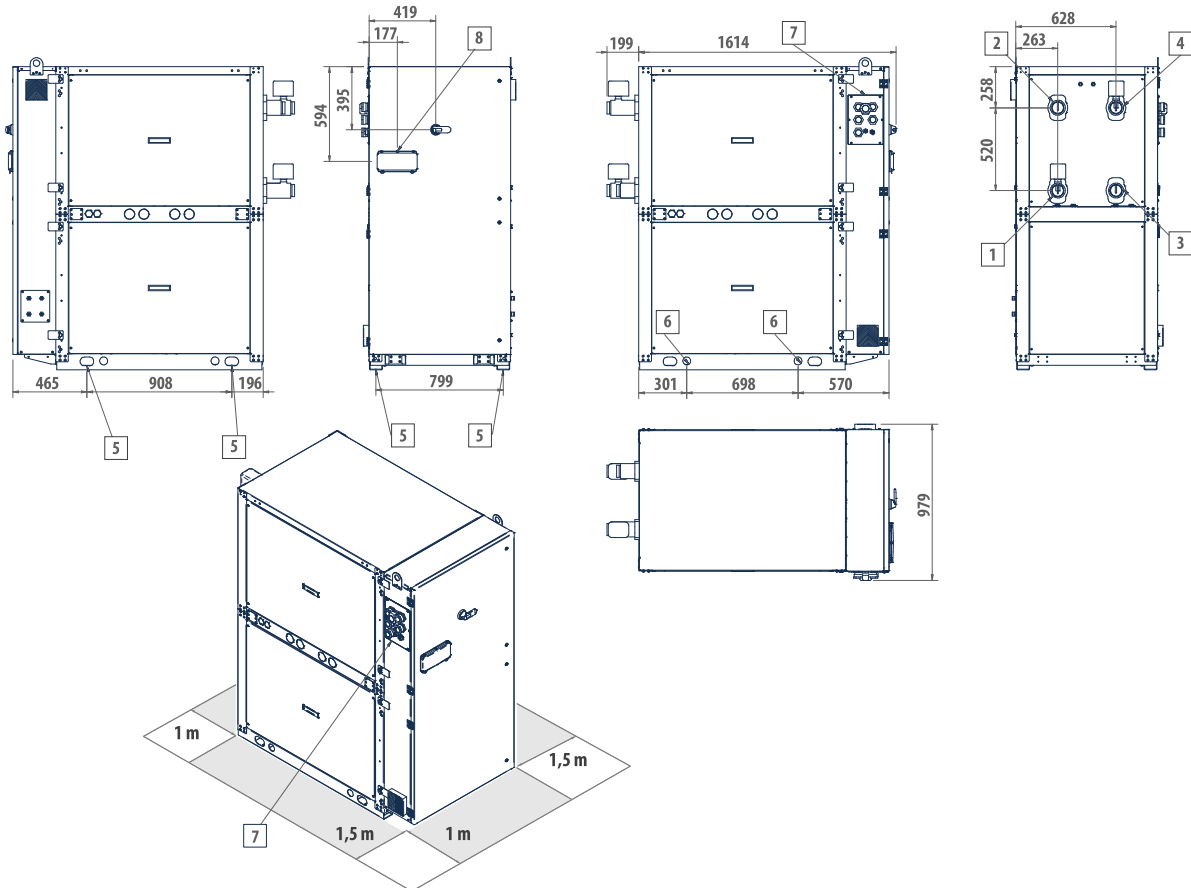
WBZ 122



LEGEND

- | | |
|---|---|
| 1 | User side water inlet 2" 1/2 Victaulic |
| 2 | User side water outlet 2" 1/2 Victaulic |
| 3 | Source side water outlet 2" 1/2 Victaulic |
| 4 | Source side water inlet 2" 1/2 Victaulic |
| 5 | Vibration dampers |
| 6 | Lifting points |
| 7 | Power supply input |
| 8 | User interface |

Closing panelling available on request

For maintenance requirements, keep at least 0.5 m of clearance from the ceiling.

DIMENSIONAL DRAWINGS

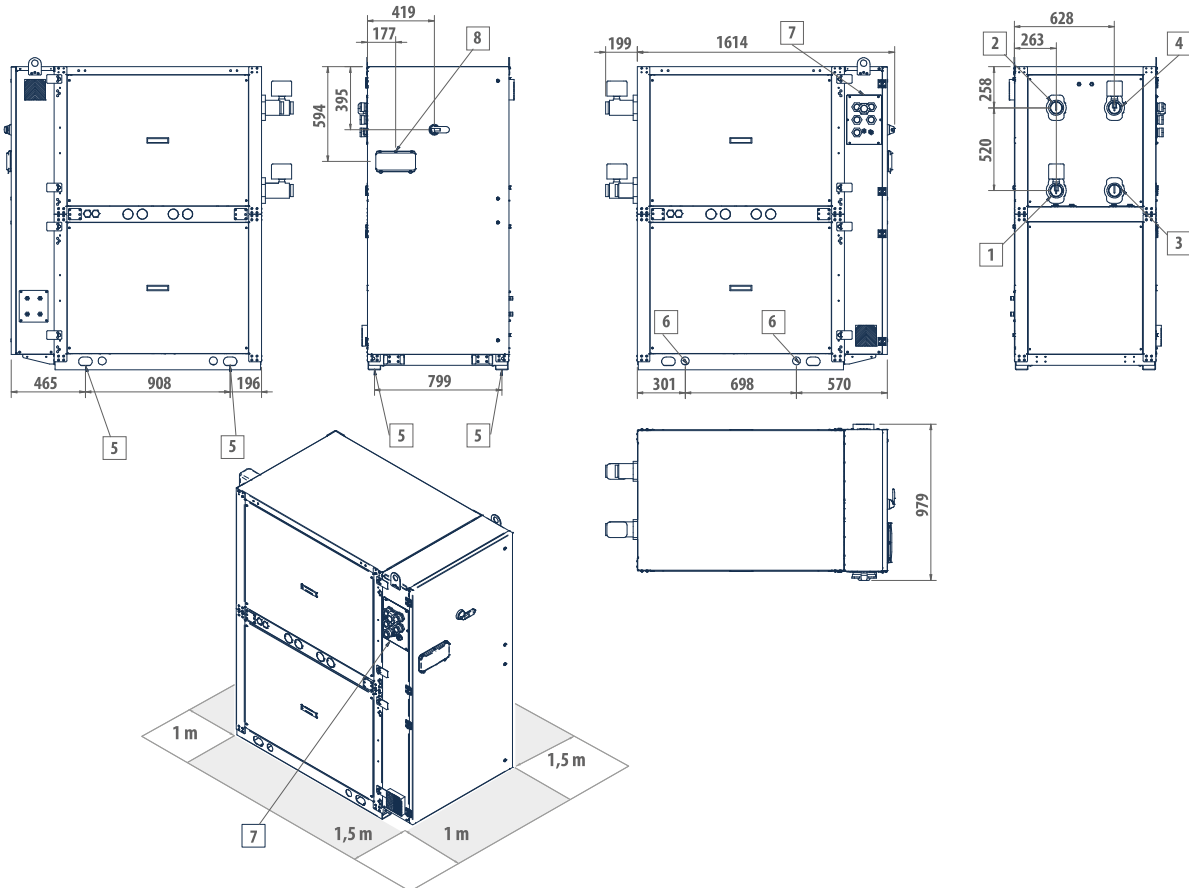
WBZ 164 - 184 - 194 - 224

LEGEND

1	User side water inlet 2" 1/2 Victaulic WBZ164W - WBZ184W - WBZ194W / 3" Victaulic WBZ224W
2	User side water outlet 2" 1/2 Victaulic WBZ164W - WBZ184W - WBZ194W / 3" Victaulic WBZ224W
3	Source side water inlet 2" 1/2 Victaulic WBZ164W - WBZ184W - WBZ194W / 3" Victaulic WBZ224W
4	Source side water outlet 2" 1/2 Victaulic WBZ164W - WBZ184W - WBZ194W / 3" Victaulic WBZ224W
5	Vibration dampers
6	Lifting points
7	Power supply input
8	User interface

Closing panelling available on request
For maintenance requirements, keep at least 0.5 m of clearance from the ceiling.