

Outdoor packaged unit

GLE 680 - 1080 kW



AZL gas leak detection



R-454B refrigerant



Scroll compressor



Cooling only



Heating/
Cooling

PLUS

- » High efficiency when operating at partial load
- » Electronically controlled electric expansion valve
- » Incorporable hydronic kit
- » High configurability and wide availability of accessories
- » Compact dimensions
- » Use of low GWP refrigerant
- » 3 different acoustic configurations

The "W" configuration of the finned block heat exchangers makes it possible to have a large amount of exchange surface with a small footprint, thereby resulting in machines with high power density.

Multi-scroll solutions for reliability and high efficiency at partial loads with low GWP refrigerant

GLE is Galletti's range of air-cooled big capacity packaged chillers and heat pumps for outdoor installation featuring R454B refrigerant. R454B is a next generation A2L refrigerant with a GWP of only 467, one of the lowest on the market. This GWP value ensures that the GLE range complies with the gradual reduction of greenhouse gas emissions required by the F-GAS regulation, down to the stricter limits foreseen for 2030.

The range consists of 6 models with cooling capacities from 650 to 1130 kW, available in cooling only or reversible heat pump versions. The sizing and choice of individual components is intended to reduce energy consumption with a view to saving energy not only on each individual chiller but on the entire system. The high number of capacity control steps allows the unit to adapt its power to the actual needs of the system, with particular gains in efficiency under partial load conditions compared to traditional screw compressors.

The unit is suitable for being installed in environments where noise abatement is fundamentally important, thanks to the possibility of choosing from three sound-proofing set-ups.

The use of top quality components at the cutting edge of technology in the cooling, hydraulic, and electrical systems makes GLE chillers state of the art in terms of efficiency, reliability, and operating limits.

In fact, the ability to produce water from -10°C to 55°C, and full load operation with external air from -10°C to 45°C.

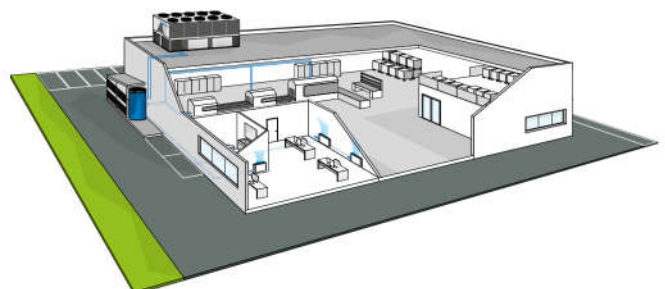

MAIN COMPONENTS

Structure

Painted galvanised sheet steel structure for an effective resistance to corrosive agents. Compressor compartment located below the finned heat exchangers to reduce the dimensions without compromising performance.

Compressors

Hermetic scroll compressors driven by electric motors and connected in tandem or trio version to maximize efficiency at partial loads.

Electronically controlled electric expansion valve

It represents, together with the compressor, the key component for the proper functioning of the unit. It optimizes the machines' operation at partial loads and increases the average seasonal energy efficiency.

Heat exchangers

Finned heat exchangers with copper pipes and aluminum fins in a "W"

Very low GWP refrigerant

Use of R454B refrigerant with low environmental impact. R454B is a next-generation A2L refrigerant with a GWP of only 467, one of the lowest on the market. This GWP value ensures the range complies with the gradual reduction of quotas of greenhouse refrigerants in the European market required by the F-GAS regulation, down to the stricter limits foreseen for 2030

Hydraulic kit

Option of choosing one or two pumps at standard or high head to meet system requirements, suitable for operation with glycol up to 30% and can be combined with a heat buffer tank.

CONFIGURATOR

The models are completely configurable by selecting the version and the options. To the right is shown an example of configuration.

Version	Field	1	2	3	4	5	6	7	8	9	10	11	12
GLE658CL		0	B	4	S	0	C	0	2	0	0	M	3

To verify the compatibility of the options, use the selection software or the price list.

AVAILABLE VERSIONS

Only cooling versions

GLE...CS	Standard execution
GLE...CL	Low noise execution
GLE...CQ	Super low noise execution

Heat pump versions

GLE...HS	Reversible, standard execution
GLE...HL	Reversible, low noise execution
GLE...HQ	Reversible, quite execution

CONFIGURATION OPTIONS

1 Power supply	8 Remote communication
0 400/3/50 + N	0 Absent
1 400V-3-50Hz + transformer	1 RS485 serial card (Modbus or Carel protocol)
2 400/3/50 + N + Circuit breakers	4 BACNET IP/pCOWeb serial board
3 400/3/50 + circuit breakers	5 BACNET IP / pCOWeb serial board + supervision software
2 Refrigerant	9 Special coils / Protective treatments
B R454B	0 Standard
3 User side water pump	B Epoxy pre-painted fin and overall painting
0 Absent	C Cataphoresis
1 Single pump	H Hydrophilic
2 Oversize single pump	R Copper / copper
5 Double pump in timed rotation	10 Packing
6 Oversize double pump in timed rotation	0 Standard
7 Single modulating pump (electr. Flow switch included)	1 Wooden cage
8 Single HP modulating pump (electr. Flow switch included)	2 Wooden crate
9 Double modulating pump (standby rotation) (electr. Flow switch included)	11 Anti vibration shock mounts
4 Double HP modulating pump (standby rotation) (electr. Flow switch included)	0 Absent
4 Water buffer tank	G Rubber vibration dampers at the base of the unit
0 Absent	M Spring vibration dampers at the base of the unit
S Inertial tank on user side	12 Maintenance kit
5 Partial heat recovery (condensation control mandatory)	0 Absent
0 Absent	S Shut-off valves on compressor tandem / trio
D Desuperheater (recovery of 40% of Pf in rated conditions)	13 Documentation language
6 Air flow modulation	D German
C Condensation control by phase-cut fans	F French
E Condensation control with "EC brushless" electronic control fans	G English
7 Antifreezing kit	I Italian
0 Absent	N Dutch
E Protecting the water exchanger (standard machine)	P Polish
P Protecting the water exchanger and pump	R Russian
S Protecting the water exchanger, pump and tank	S Spanish

ACCESSORIES

A Power factor capacitors	L Filter shut-off kit (solenoid and tap on liquid line)
B Soft starter	M Special cable according to VDE regulation
C Service kit (advanced controller required)	N Remote control panel for programmable microprocessor
D Pair of couplings Victaulic	P Outdoor finned coil heat exchanger protection grille
E ON/OFF status of the compressors	Q Finned battery metal filters
F Remote control for step capacity limit (advanced controller required)	R Y-shaped water filter (loose delivered)
G Configurable digital alarm board (advanced controller required)	S Unit without refrigerant
H Set point compensation outdoor temperature probe	T Measurement and limitation of the absorbed current
I Refrigerant pressure gauges	

Chillers and HP with Low GWP refrigerant GLE

GLE C WATER CHILLERS RATED TECHNICAL DATA

GLE		658	748	818	900	942	1072
Power supply		400 / 3+N / 50					
Cooling capacity	(1) kW	654	752	818	958	996	1132
Total power input	(1) kW	224	250	285	316	328	397
EER	(1)	2,92	3,00	2,87	3,03	3,04	2,85
SEER	(2)	4,88	4,97	4,94	5,09	5,32	5,27
Water flow	(1) l/h	112293	129189	140534	164558	171168	194427
Water pressure drop	(1) kPa	21	24	28	32	34	49
Available pressure head - LP pumps	(1) kPa	234	189	154	199	191	146
Available pressure head - HP pumps	(1) kPa	263	286	272	295	287	244
Maximum current absorption	A	527	666	647	749	787	907
Start up current	A	620	812	807	873	800	987
Compressors / circuits		8/4	8/4	8/4	10/4	12/4	12/4
Buffer tank volume	dm ³	1040	1040	1040	1040	1040	1040
Sound power level	(3) dB(A)	99	99	99	100	100	100
Sound power level, low-noise version	(3) dB(A)	97	97	97	98	98	98
Sound power level quiet version	(3) dB(A)	96	96	96	97	97	97
Weight without options	kg	4994	5564	5564	6428	6630	7440

(1) Outdoor air temperature 35°C, water temperature 12°C / 7°C (EN14511:2022)

(2) η efficiency values for heating and cooling are respectively calculated by the following formulas: $[\eta = SCOP / 2,5 - F(1) - F(2)]$ e $[\eta = SEER / 2,5 - F(1) - F(2)]$. For further information, please refer to the technical document "ErP 2009/125/EC DIRECTIVE" in the catalogue introducing pages, or to the EN14825:2022 regulation.

(3) Sound power level measured according to ISO 9614.

GLE H HEAT PUMPS RATED TECHNICAL DATA

GLE			658	748	818	900	942	1072
Power supply		V-ph-Hz	400 / 3+N / 50					
Cooling capacity	(1)	kW	654	749	812	937	977	1170
Total power input	(1)	kW	224	252	287	328	339	382
EER	(1)		2,92	2,96	2,83	2,86	2,88	3,06
SEER	(2)		4,88	4,91	4,87	4,78	5,03	5,40
Water flow	(1)	l/h	112293	128628	139550	161049	167925	200993
Water pressure drop	(1)	kPa	21	24	27	31	33	46
Available pressure head - LP pumps	(1)	kPa	234	190	157	204	196	139
Available pressure head - HP pumps	(1)	kPa	263	286	273	300	292	238
Heating capacity	(3)	kW	666	746	821	995	1030	1190
Total power input	(3)	kW	211	238	264	310	322	382
COP	(3)		3,15	3,13	3,11	3,21	3,20	3,12
Water flow	(3)	l/h	115645	129601	142675	172793	178947	206697
Water pressure drop	(3)	kPa	22	23	27	34	37	47
Available pressure head - LP pumps	(3)	kPa	223	187	147	184	174	124
Available pressure head - HP pumps	(3)	kPa	257	284	268	280	270	222
Maximum current absorption		A	527	591	647	757	795	922
Start up current		A	620	759	807	881	808	1002
Buffer tank volume		dm ³	1040	1040	1040	1040	1040	1040
Compressors / circuits			8/4	8/4	8/4	10/4	12/4	12/4
Sound power level	(4)	dB(A)	99	99	99	100	100	101
Sound power level, low-noise version	(4)	dB(A)	97	97	97	98	98	99
Sound power level quiet version	(4)	dB(A)	96	96	96	97	97	98
Length		mm	5060	6635	6635	8635	8635	10635
Depth		mm	2256	2256	2256	2256	2256	2256
Height		mm	2650	2650	2650	2650	2650	2650
Weight without options		kg	5196	5506	5642	7200	7508	8840

(1) Outdoor air temperature 35°C, water temperature 12°C / 7°C (EN14511:2022)

(2) η efficiency values for heating and cooling are respectively calculated by the following formulas: [$\eta = SCOP / 2,5 - F(1) - F(2)$] e [$\eta = SEER / 2,5 - F(1) - F(2)$]. For further information, please refer to the technical document "ErP 2009/125/EC DIRECTIVE" in the catalogue introducing pages, or to the EN14825:2022 regulation.

(3) Outdoor air temperature dry bulb 7°C / wet bulb 6°C, water temperature 40°C / 45°C (EN14511:2022)

(4) Sound power level measured according to ISO 9614

Note: For dimensional drawing of heat pump models, contact the manufacturer.

DIMENSIONAL DRAWINGS

GLE 658 C

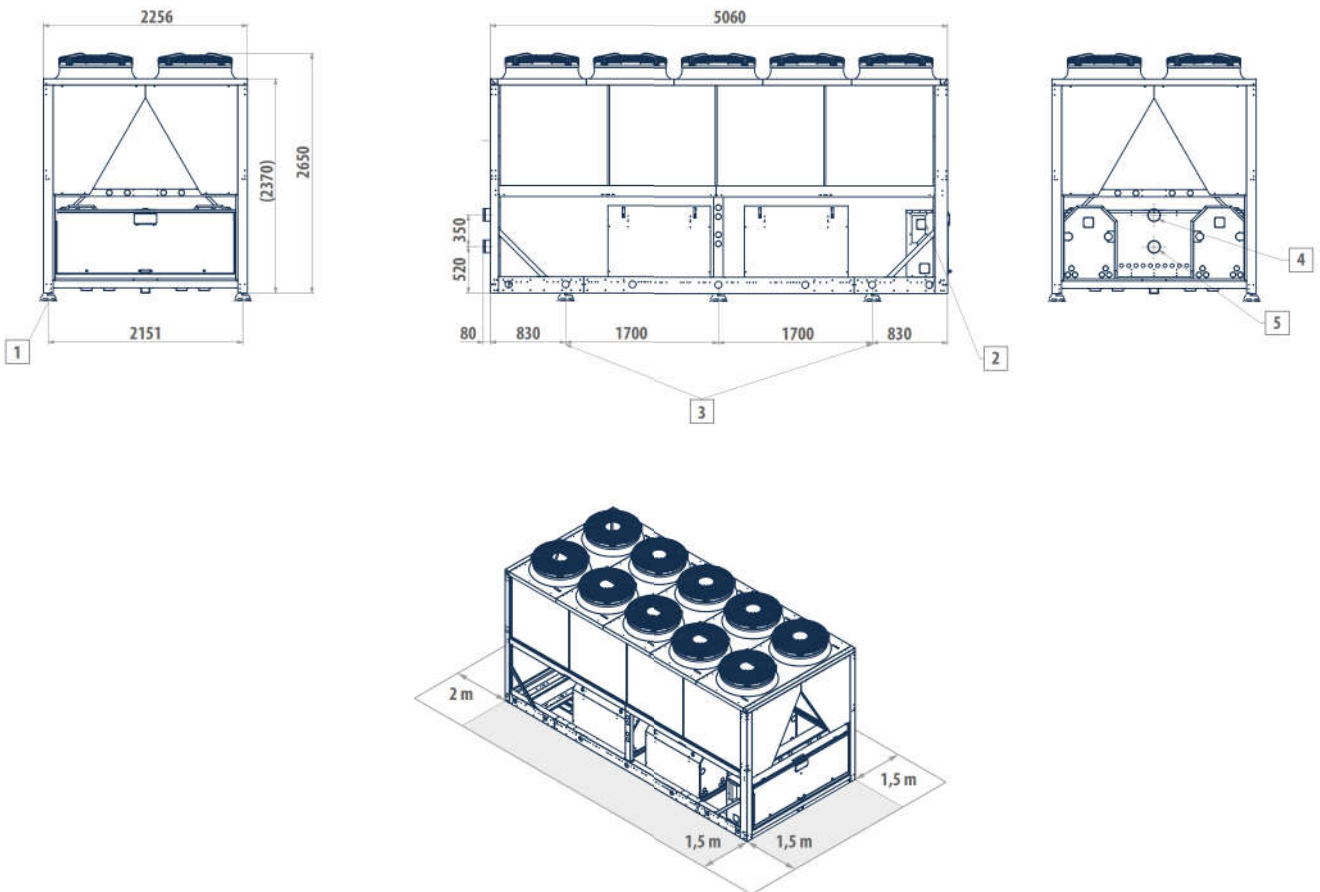

LEGEND

- | | |
|---|-----------------------------|
| 1 | Vibration dampers |
| 2 | Power supply input |
| 3 | Lifting points |
| 4 | Water inlet (5" Victaulic) |
| 5 | Water outlet (5" Victaulic) |

DIMENSIONAL DRAWINGS

GLE 748 - 818 C

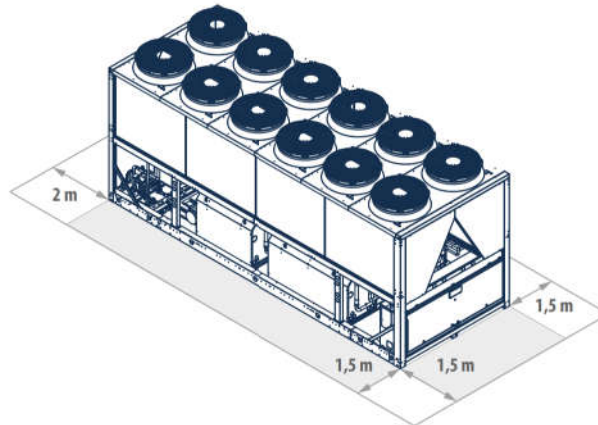
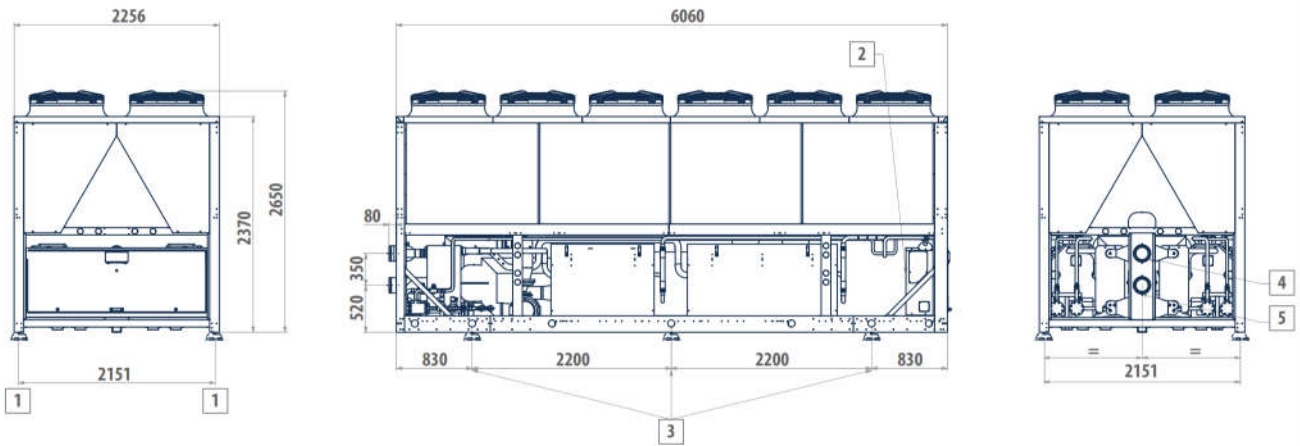

LEGEND

- | | |
|---|-----------------------------|
| 1 | Vibration dampers |
| 2 | Power supply input |
| 3 | Lifting points |
| 4 | Water inlet (6" Victaulic) |
| 5 | Water outlet (6" Victaulic) |

Chillers and HP with Low GWP refrigerant GLE

DIMENSIONAL DRAWINGS

GLE 900 - 942 C

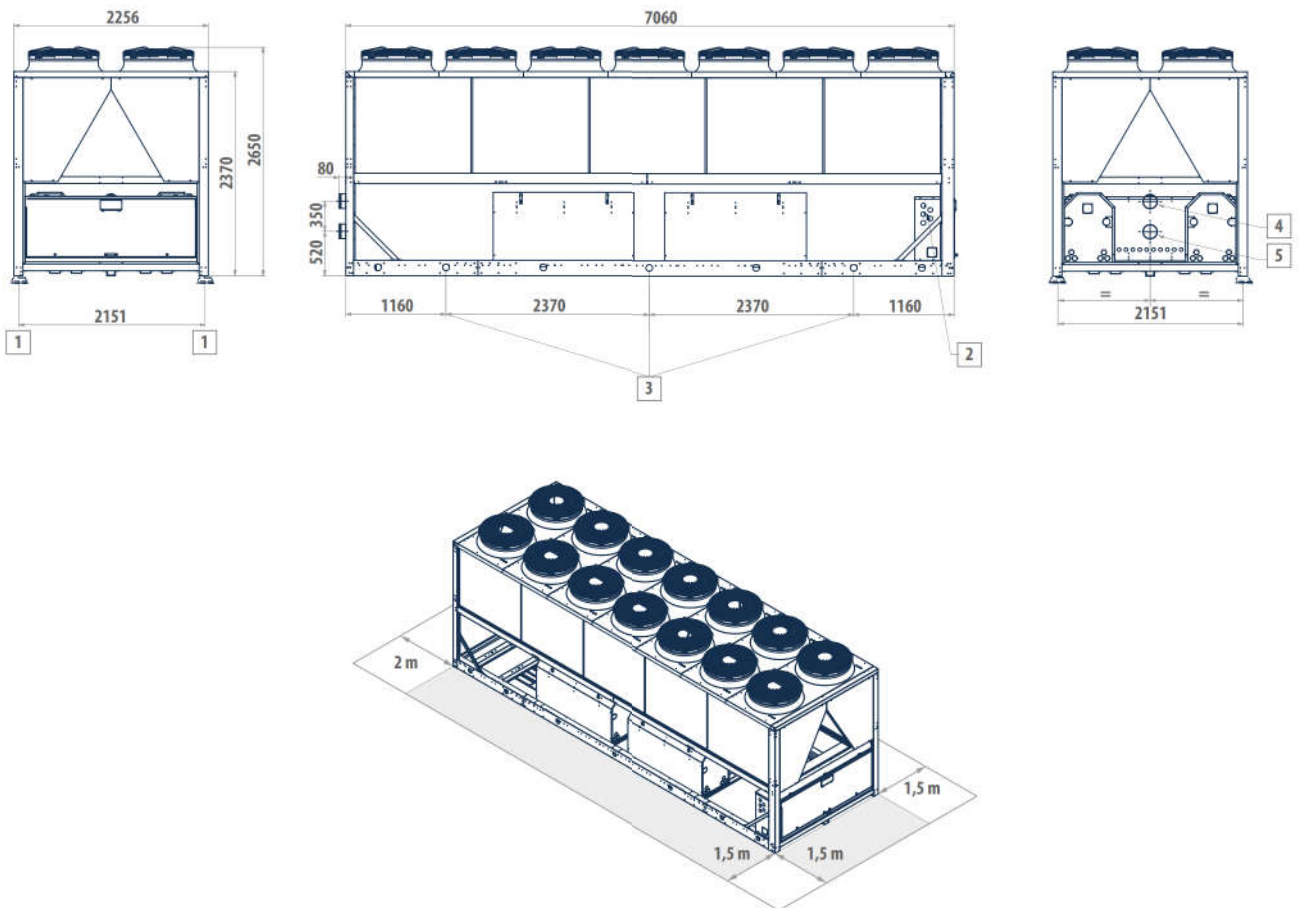

LEGEND

- | | |
|---|-----------------------------|
| 1 | Vibration dampers |
| 2 | Power supply input |
| 3 | Lifting points |
| 4 | Water inlet (6" Victaulic) |
| 5 | Water outlet (6" Victaulic) |

DIMENSIONAL DRAWINGS

GLE 1072 C

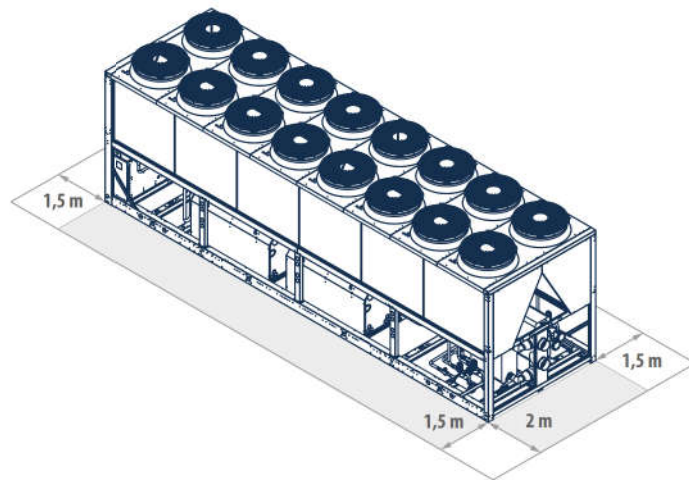
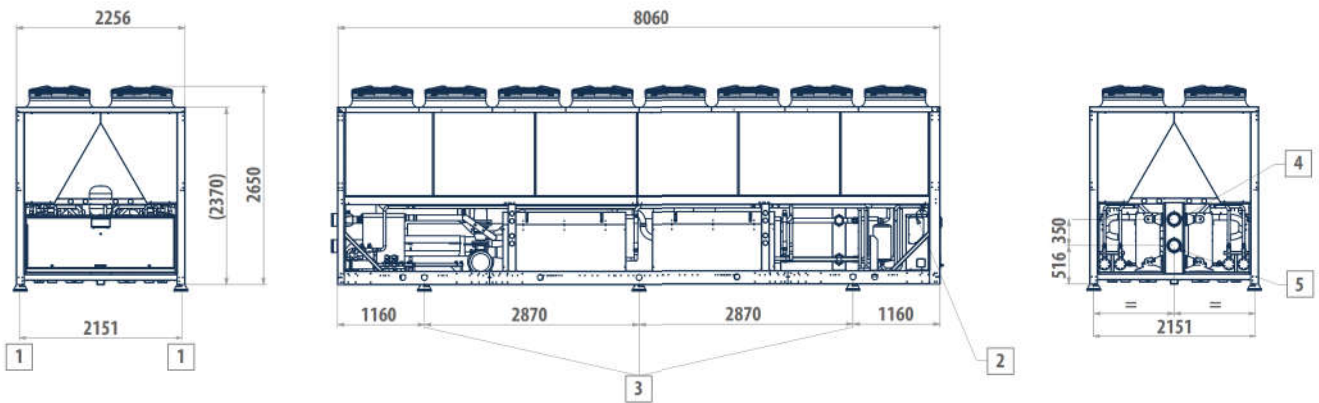

LEGEND

1	Vibration dampers
2	Power supply input
3	Lifting points
4	Water inlet (6" Victaulic)
5	Water outlet (6" Victaulic)
6	Optional heat recovery water outlet (Victaulic 4")
7	Optional heat recovery water inlet (Victaulic 4")